

SERVICE MANUAL

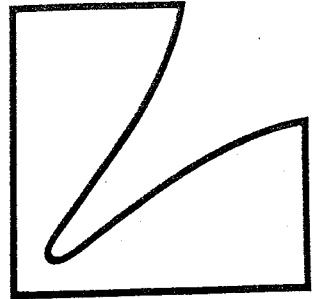

SOLID STATE STEREO
INTEGRATED AMPLIFIER

L-3



INTERNAL VIEW

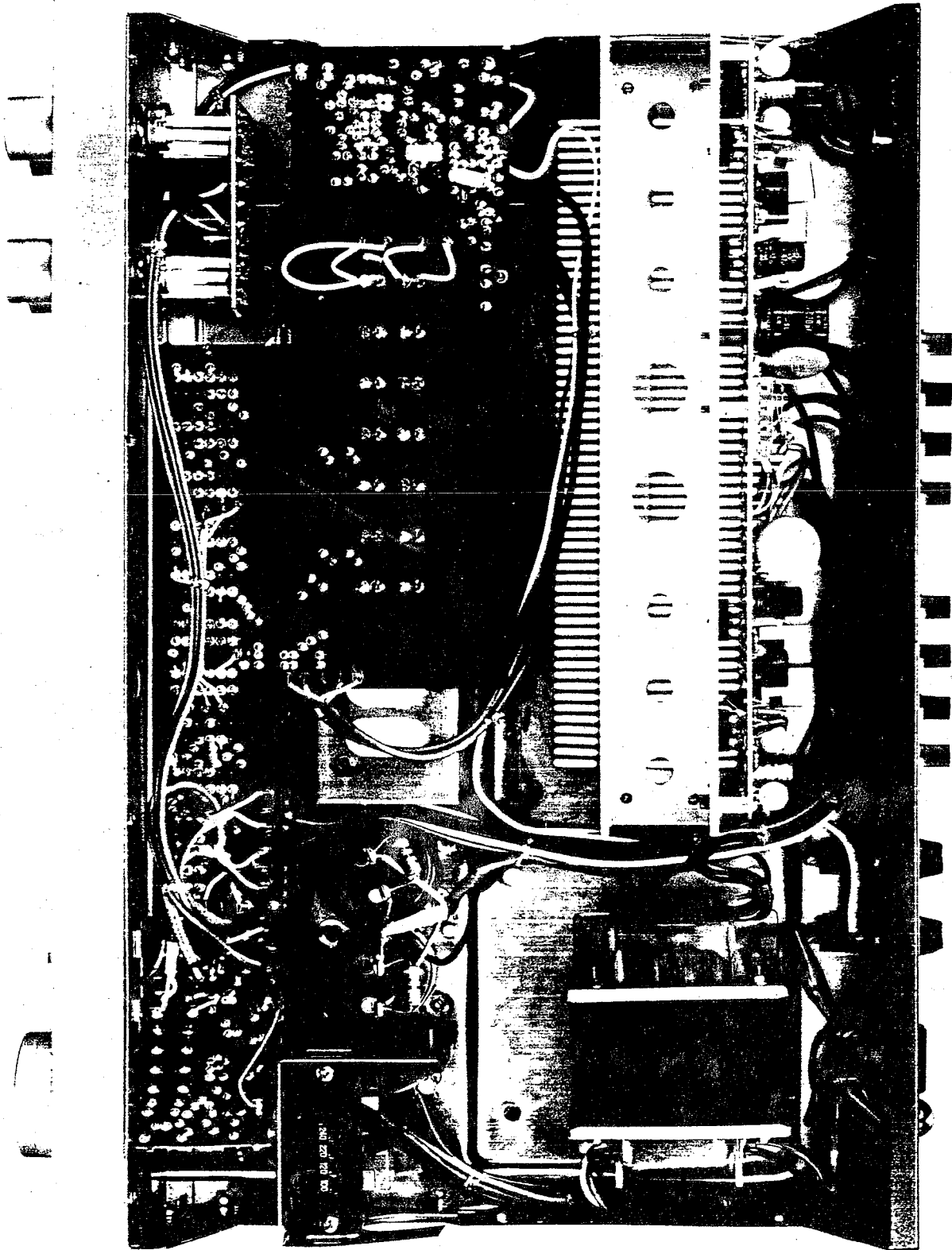

ALIGNMENT PROCEDURE

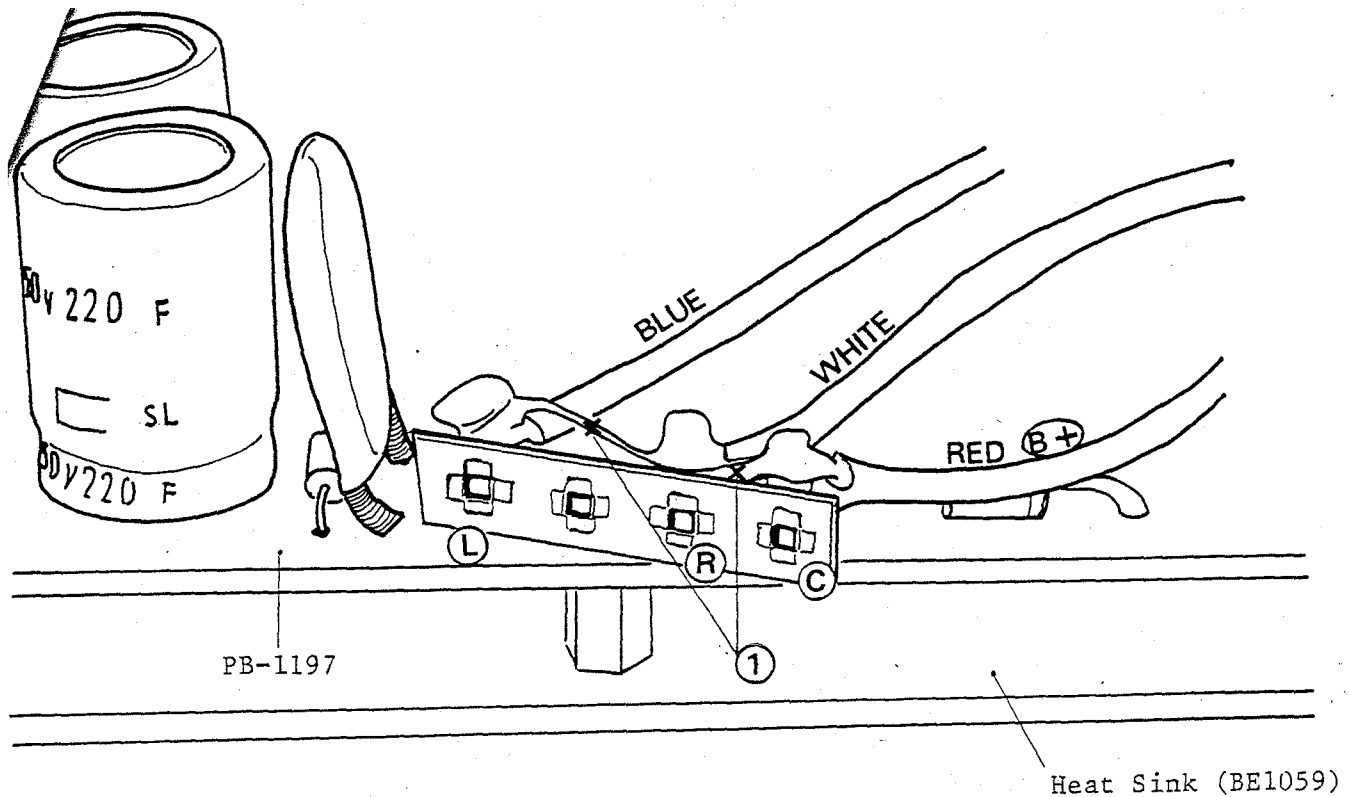

Idle Adjustment

- (1) Cut the jumper lead, as described in the illustration.
- (2) Connect a resistor 10 ohms 1W across (L) and (C).
Connect a DC amperemeter (full scale 250 - 300mA) between (R) and (C). (polarization: (C) ⊕) Adjust VR402b to obtain 50mA reading on the meter. (R-ch idle adjust)
- (3) Disconnect the lead of the resistor connected to (L), and connect it to (R), leaving the lead connected to (C) as it is. Connect a DC amperemeter between (L) and (C). (polarization: (C) ⊕) Adjust VR402a to obtain 50mA reading on the meter. (L-ch idle adjust)
- (4) Connect (C) - (R), and (R) - (L) again by use of jumper leads.
- (5) This adjustment should be done 1 minute after turning the power on.

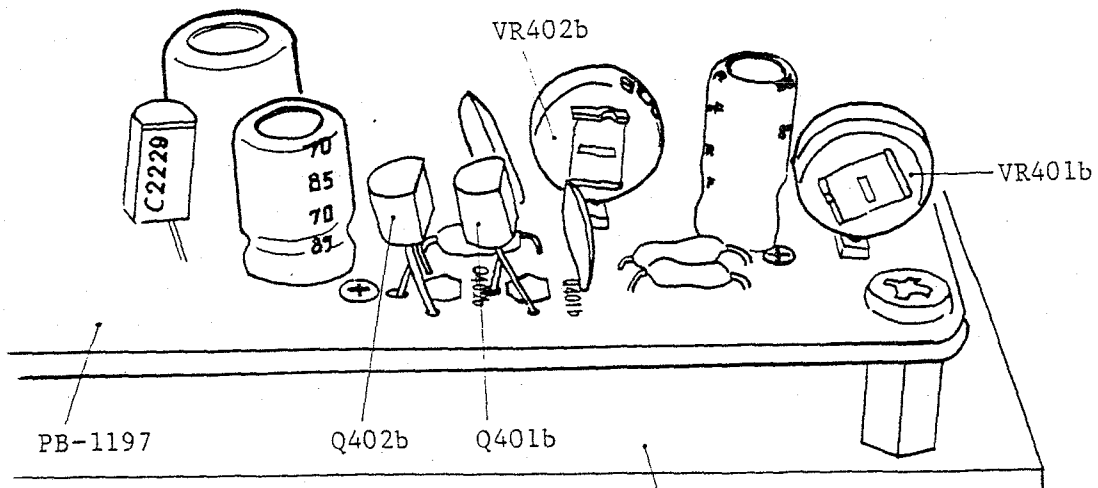

DC Offset Adjustment

- (1) Connect a DC voltmeter (full scale 100 - 300mV) to the speaker terminals on the rear panel.
- (2) Adjust VR401a (L-ch) and VR401b (R-ch) respectively to obtain 0V reading on the meter.
- (3) This adjustment should be done 1 minute after turning the power on.

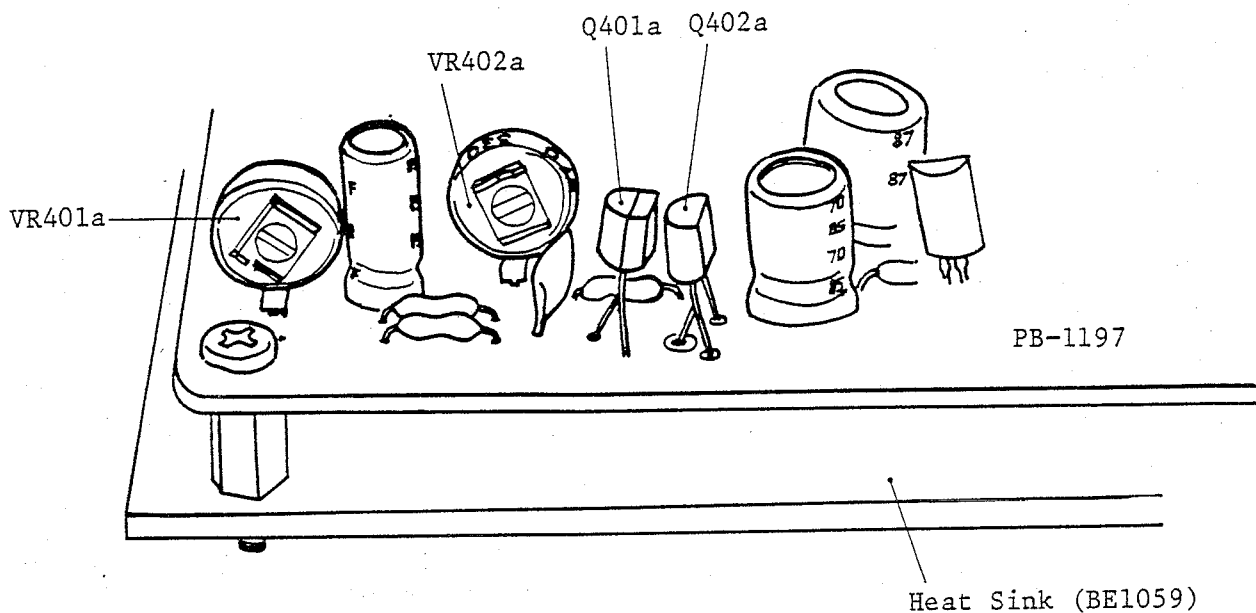

EXPLODED VIEW

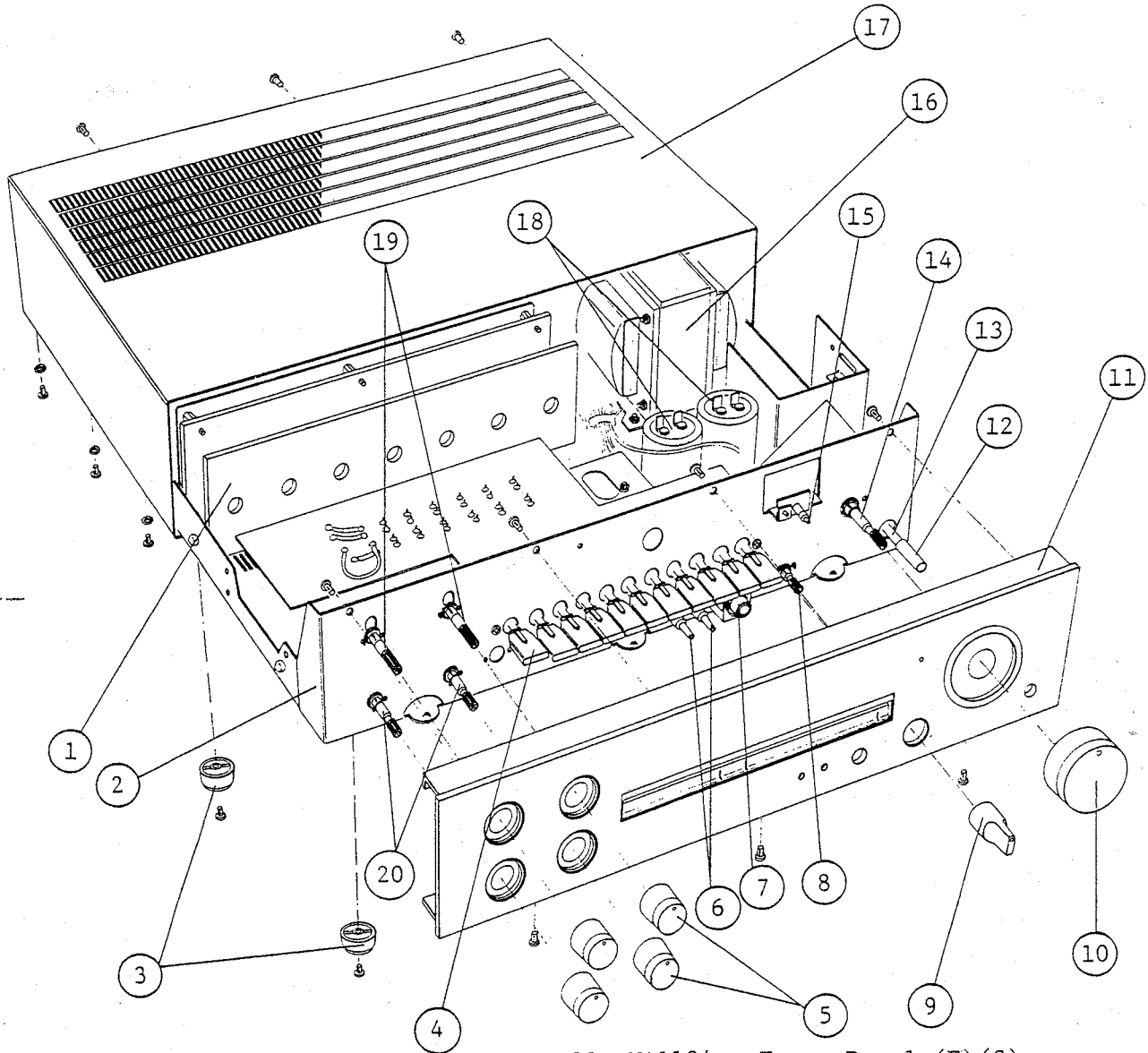

- | | | | |
|------------|-------------------------------|------------|-----------------------------|
| 1. BE1059 | Heat Sink | 11. WA1134 | Front Panel (E) (S) |
| 2. UB1048 | Sub Panel | WA1142 | Front Panel (U) |
| 3. WN0007 | Leg | 12. WJ1089 | Mould Knob (power) |
| 4. WJ1106 | Mould Knob | 13. SP0063 | Push Switch (power) |
| 5. WH1074 | Knob Set (tone cont.) (E) (S) | SP0090 | Push Switch (power) (E) (S) |
| WH1080 | Knob Set (tone cont.) (U) | 14. RV0204 | Volume 200k-B |
| 6. WJ1107 | Mould Knob (sp. select.) | 15. TD0096 | LED, SLC25UR (red) |
| 7. AJ0014 | Headphone Jack | 16. PT2250 | Power Trans. (E) |
| 8. RV0205 | Volume 250k-MN (balance) | PT2251 | Power Trans. (S) |
| 9. WH1079 | Knob Set (balance) (U) | PT2271 | Power Trans. (U) |
| WH1047 | Knob Set (balance) (E) (S) | 17. UG1010 | Bonnet (E) (S) |
| 10. WH1081 | Knob Set (volume) (U) | UG1015 | Bonnet (U) |
| WH1073 | Knob Set (volume) (E) (S) | 18. CE1430 | Electrolytic 6800uF 50V |
| | | 19. RV0206 | Treble Cont. 50k-B |
| | | 20. RV0207 | Bass Cont. 100k-B |

REMARKS

Capacitors: C.....ceramic, E.....electrolytic, M.....mylar, G.....G capacitor
 S.....styrol, T.....tantalum, Mi.....mica, MP....MP capacitor
 O.....oil capacitor, TRIM.....trimmer capacitor, AC....AC capacitor
 BP....electrolytic Bi-Polar type

Resistors: ±5%, 1/4W, unless specified otherwise

Type: (S)..... model for north European countries
 (U)..... model for U.S.A. and CANADA
 (J)..... model for JAPAN

PB1194

SYMBOL NO.	STOCK NO.	DESCRIPTION	LOCA-TION
R101ab	RB0224	56K	
102ab	246	470K	
103	210	15K	
104ab	254	1M	
105ab	182	1K	
106ab	234	150K	
		(E) (S)	
107ab	174	470	
108ab	230	100K	
109ab	222	47K	
110ab	180	820	
111ab	184	1.2K	
112ab	220	39K	
113ab	252	820K	
114ab	174	470	
115ab	204	8.2K	
116ab	242	330K	
117ab	254	1M	
118ab	254	1M	
119ab	254	1M	
120ab	254	1M	
121ab	202	6.8K	
122ab	202	"	
123ab	208	12K	
124ab	216	27K	
125	RS1078	680 1/4 F	
126	RB0220	39K	
127ab	234	150K	
		(E) (S)	
Q101ab	TR0125	2SA836	E
102ab	TR0025	2SC1345	E
C101ab	CE0173	3.3u	25V E
102	CE0079	220u	16V E
103ab	CC0008	150P	50V C
104ab	CC0003	4.7P	50V C
105ab	CE0074	10u	16V E
106ab	CQ0130	1000P	50V M
107ab	CQ0130	1000P	50V M
108ab	CQ0122	6800P	50V M

SYMBOL NO.	STOCK NO.	DESCRIPTION	LOCA-TION
109ab	CE0189	0.47u 50V E	
110ab	CQ0121	0.12u 50V M	
111ab	CQ0330	3300P 50V M	
112ab	CC0011	470P 50V C	
113ab	CQ0031	0.033 50V M	
114ab	CE0068	47u 10V E	
115	CE0103	100u 50V E	
116	CK0145	0.022u 50V C	
117	CK0159	0.1uF 25V C	
118	CK0159	0.1uF 25V C	
119ab	CC0005	33P 50V C	
SW101	SP0106	Push SW 11key	
102	"	"	
103	"	"	
104	"	"	
105	"	"	
106	"	"	
107	"	"	
108	"	"	
109	"	"	
110	"	"	
111	"	"	

PB1195A

SYMBOL NO.	STOCK NO.	DESCRIPTION	LOCATION
R201	RB0218	33K	
202ab	RB0246	470K	
203	RD0004	1M 1/4	
204	RB0190	2.2K	
205	RD0022	47K 1/4	
206	RB0182	1K	
207	RB0214	22K	
208	RB0198	4.7K	
209	RB0242	330K	
210	RS1092	2.2K F 1/4	
C201	CE0078	100μ 16V E	
202ab	CE0183	1μ 50V E	
203ab	CC0037	5P 25V C	
204ab	CE0173	3.3μ 25V E	
205	CE0095	100μ 35V E	
206	CK0145	0.022μ 50V C	
Q201ab	TR0125	2SA836 E	
202ab	TR0025	C1345 E	
VR201	RV0205	250K MN	
202	RV0204	200K B	

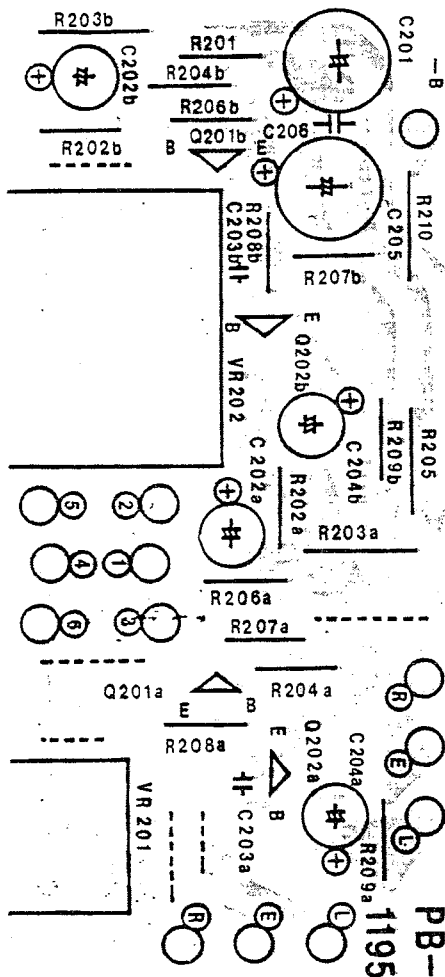

PB1196

SYMBOL NO.	STOCK NO.	DESCRIPTION	LOCATION
R301ab	RB0212	18K	
302ab	186	1.5K	
303ab	186	1.5K	
304ab	212	18K	
305ab	190	2.2K	
306ab	220	39K	
307ab	244	390K	
308ab	182	1K	
309ab	200	5.6K	
310ab	188	1.8K	
311	RS1094	3.3K F 1/4	
C301ab	CQ0124	0.022μ 50V M	
302ab	CQ0130	1000P 50V M	
303ab	CQ0130	1000P 50V M	
304ab	CQ0334	1800P 50V M	
305ab	CQ0334	1800P 50V M	
306ab	CE0173	3.3μ 25V E	
307ab	CC0012	10P 25V C	
308	CE0096	220μ 35V E	
309	CK0145	0.022μ 50V C	
310ab	CE0173	3.3μ 25V E	
Q301ab	TR0125	A836 E	
302ab	TR0125	A836 E	
VR301ab	RV0207	100KB	
302ab	RV0206	50KB	

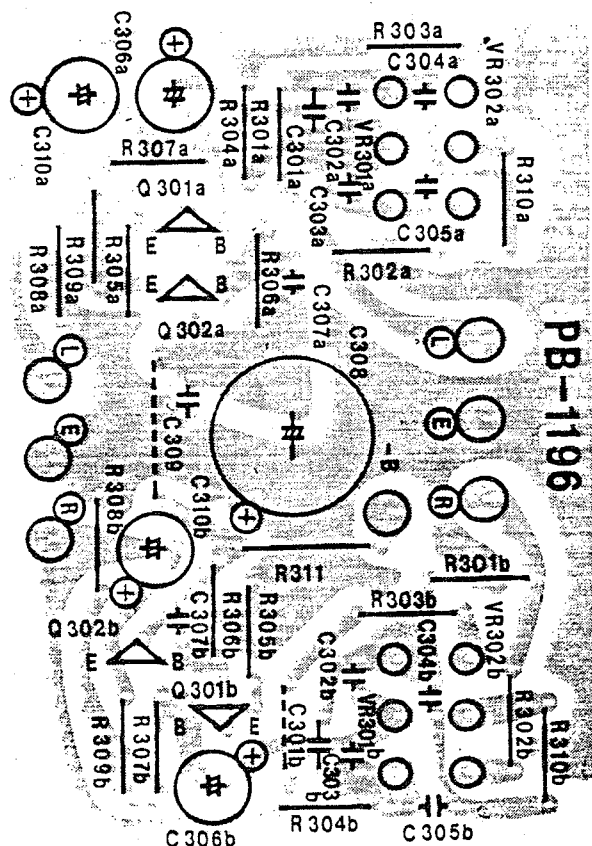

SYMBOL NO.	STOCK NO.	DESCRIPTION	LOCATION	SYMBOL NO.	STOCK NO.	DESCRIPTION	LOCATION
R401ab	RB0194	3.3K		C414	CU0012	0.01 μ 125V C	
402ab	RB0214	22K		415	CE0146	220 μ 50V E	
403ab	RB0202	6.8K		416	CE0146	220 μ 50V E	
404ab	RB0176	560		417	CE0146	220 μ 50V E	
405ab	RB0180	820		418	CC0007	100P 50V C	
406ab	RD0129	1.5K 1/2		419	CU0012	0.01 μ 125V C	
407ab	RB0188	1.8K		Q401ab	TR0193	A942 RAKK	
408ab	RB0196	3.9K		402ab	TR0193	A942 RAKK	
409ab	RB0214	22K		403ab	TR0236	C2229	
410ab	RB0178	680		404ab	TR0146	C1740	
411ab	RB0188	1.8K		405ab	TR0264	C2235	
412ab	RB0150	47		406ab	TR0263	A965	
413ab	RB0150	47		407ab	TR0262	D716	
414ab	RS0074	100 1/2 F		408ab	TR0261	B686	
415ab	RS0074	100 1/2 F		409	TR0125	A836	
416ab	RG0009	0.33		D401ab	TD0002	1N4002	
417ab	RG0009	0.33		402ab	TD0003	1N4003	
418ab	RD0158	10 1W		403	TD0106	S3V40	
419ab	RS2709	10 1W F		?	?	?	
420ab	RS0074	100 1/2 F		406	"	"	
421	RS0074	100 1/2 F		DZ401	TD0065	WZ192	
422	RB0206	10K		ab			
423	RB0182	1K		UC1092		Rear Panel U	
424	RD0150	4.7K 1W		UC1093		" S	
425ab	RB0242	330K		UC1096		" E	
426ab	RB0150	47		UC1122		" UC	
R001	RD0150	4.7K 1W		UB1048		Sub Panel	
002	RD0150	4.7K 1W		SW001	SP0063	Push SW U	
L401ab		LUX1004-2 MH			SP0090	" E.J.S	
F401	BF0201	Fuse 0.1A (T)		SW502	SP0107	Push SW 2key	
	BF0074	Fuse 0.5A		ab	AS0002	DIN CONNE.	
	BF0111	Fuse 0.5A			AH0016	1P Fuse Holder	
		(E)				E.J.U	
C401ab	CE0173	3.3 μ 25V E			AH0019	1P Fuse Holder	
402ab	CC0009	220P 50V C				S	
403ab	CE0077	47 μ 16V E		F001	BF0079	3A U	
404ab	CE0146	220 μ 50V E			BF0014	1.5A EK	
405ab	CE0094	47 μ 35V E			BF0117	3A EZ.J	
406ab	CC0005	33P 50V C			BF0208	1AT 250V S	
407ab	CK0157	0.04 μ 25V C			PT2250	P2250	
408ab	CE0098	1 μ 50V E				Power Trans E	
409ab	CK0146	0.04 μ 50V C			PT2251	P2251 S	
410ab	CQ0332	0.039 μ 50V M			PT2271	P2271 U	
411ab	CE0102	47 μ 50V E		R003	RD0339	560 Ω 1W	
412ab	CE0098	1 μ 50V E		R004	"	"	
413ab	CK0146	0.04 μ 50V C		C001	CE1430	6800 μ F 50V E	
VR401ab	RT0026	Semifix 4.7K-B		C002	"	6800 μ F 50V E	
VR402ab	RT0013	" 330 Ω -B					

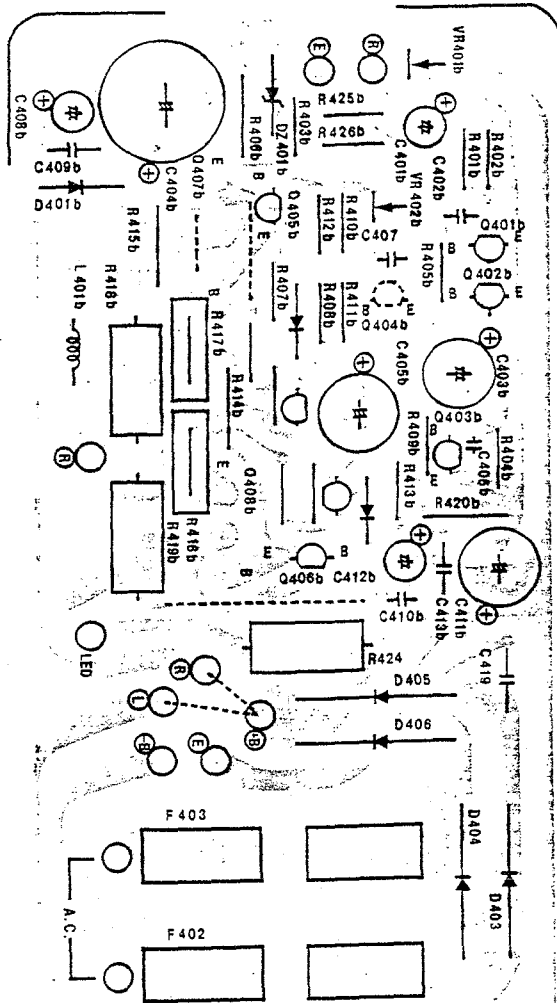

CAUTION: REPLACE WITH SAME TYPE FUSE
 ATTENTION: REMPLACER PAR UN
 FUSIBLE DU MEME TYPE.

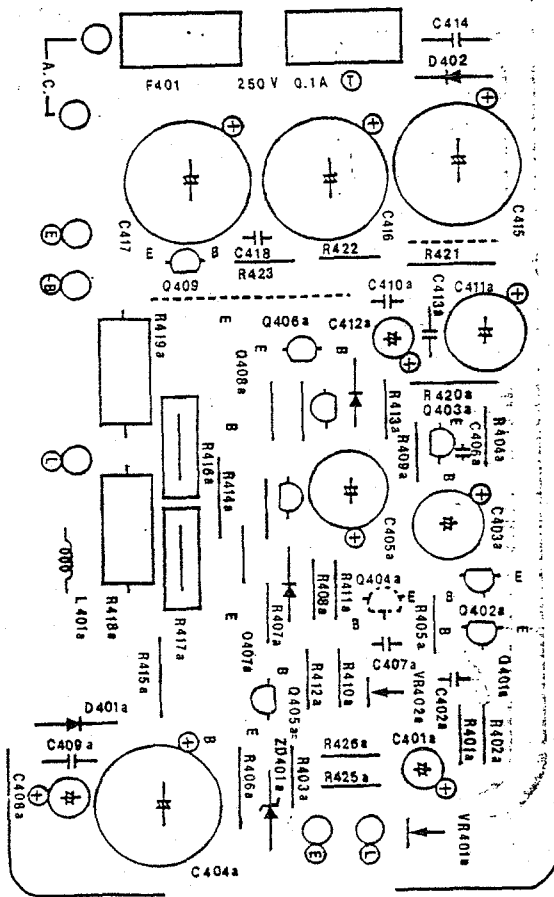

C1740 (TR0146)

Absolute Maximum Ratings (Ta = 25°C)

SYMBOL	RATING	UNIT
V _{CBO}	50	V
V _{CEO}	40	V
V _{EBO}	5	V
I _C	100	mA
P _C	300	mW
T _j	125	°C
T _{stg}	-55 - 125	°C

ELECTRICAL CHARACTERISTICS (Ta = 25°C)

SYMBOL	CONDITION	MIN.	TYP.	MAX.	UNIT
BV _{CEO}	I _C =1mA	40	-	-	V
BV _{CBO}	I _C =50uA	50	-	-	V
BV _{EBO}	I _E =50uA	5	-	-	V
I _{CBO}	V _{CB} =30V	-	-	0.5	μA
I _{EBO}	V _{EB} =4V	-	-	0.5	μA
V _{CE(sat)}	I _C /I _B =50mA/5mA	-	-	0.4	V
h _{FE}	V _{CE} /I _C =6V/1mA	120	-	560	-
f _T	V _{CE} =12V, I _E =-2mA	-	180	-	MHz
C _{ob}	V _{CB} =12V, I _E =0, f=1MHz	-	2.0	3.5	pF

2SA942RAKK (TR0193)

Absolute Maximum Ratings (Ta = 25°C)

SYMBOL	RATING	UNIT
V _{CBO}	-90	V
V _{CEO}	-90	V
V _{EBO}	-5	V
I _C	-50	mA
I _E	50	mA
P _C	300	mW
T _j	125	°C
T _{stg}	-55 - 125	°C

ELECTRICAL CHARACTERISTICS (Ta = 25 ± 15°C)

SYMBOL	CONDITION	MIN.	MAX.	UNIT
I _{CBO}	V _{CB} =-90V, I _E =0	-	-0.1	μA
I _{EBO}	V _{EB} =-5V, I _C =0	-	-0.1	μA
h _{FE}	V _{CE} =-6V, I _C =-2mA	280	700	-
V _{CE(sat)}	I _C =-10mA, I _B =-1mA	-	-0.4	V
C _{ob}	V _{CB} =-10V, I _E =0, f=1MHz	-	5.0	pF
NF	V _{CE} =-6V, I _C =-0.1mA R _g =10k ohms, f=100Hz	-	6.0	dB

2SB686/2SD716 (TR0261/TR0262)

Type No.	V _{CEO} (V)	I _C (A)	P _C (W)	h _{FE}	V _{CE(sat)} MAX			f _T TYP. (MHz)
					V _{CE} (V)	I _C (A)	I _B (A)	
2SB686 / 2SD716	100	6	60	55 - 160	5	1	2.0 4 0.4	10/12

2SA836 (TR0125), 2SC1345 (TR0025)

Type No.	V _{CEO} (V)	I _C (mA)	P _C (mW)	h _{FE}	f _T (MHz)	Condition		NF (dB)	Condition		
						V _{CE} (V)	I _C (mA)		V _{CE} (V)	I _C (mA)	f (Hz)
2SA836	-55	-100	200	160 to 800	200	-12	-2	1	-6	-0.1	1k
2SC1345	50	100	200	250 to 1200	230	12	2	1	6	0.1	1k

2SA965 (TR0263)

Absolute Maximum Ratings (Ta = 25°C)

SYMBOL	RATING	UNIT
V _{CB0}	-120	V
V _{CEO}	-120	V
V _{EBO}	-5	V
I _C	-800	mA
I _E	800	mA
P _C	900	mW
T _j	150	°C
T _{stg.}	-55-150	°C

ELECTRICAL CHARACTERISTICS (Ta = 25°C)

SYMBOL	CONDITIONS	MIN.	TYP.	MAX.	UNIT
I _{CB0}	V _{OB} = -120V, I _E = 0	-	-	-100	nA
I _{EBO}	V _{EB} = -5V, I _C = 0	-	-	-100	nA
V _{(BR)CEO}	I _C = -10mA, I _B = 0	-120	-	-	V
V _{(BR)EBO}	I _E = -1mA, I _C = 0	-5	-	-	V
h _{FE}	V _{CE} = -5V, I _C = -100mA	80	-	240	
V _{CE(sat)}	I _C = -500mA, I _B = -50mA	-	-	-1.0	V
V _{BE}	V _{CE} = -5V, I _C = -500mA	-	-	-1.0	V
f _T	V _{CE} = -5V, I _E = -100mA	-	120	-	MHz
C _{ob}	V _{CB} = -10V, I _E = 0, f = 1MHz	-	-	30	pF

2SC2235 (TR0264)

Absolute Maximum Ratings (Ta = 25°C)

SYMBOL	RATING	UNIT
V _{CB0}	120	V
V _{CEO}	120	V
V _{EBO}	5	V
I _C	800	mA
I _E	800	mA
P _C	900	mW
T _j	150	°C
T _{stg}	-55 - 150	°C

ELECTRICAL CHARACTERISTICS (Ta = 25°C)

SYMBOL	CONDITIONS	MIN.	TYP.	MAX.	UNIT
V _{CB0}	V _{CB} = 120V, I _E = 0	-	-	100	nA
I _{EBO}	V _{EB} = 5V, I _C = 0	-	-	100	nA
V _{(BR)CEO}	I _C = 10mA, I _B = 0	120	-	-	V
V _{(BR)EBO}	I _E = 1mA, I _C = 0	5	-	-	V
h _{FE}	V _{CE} = 5V, I _C = 100mA	80	-	240	
V _{CE(sat)}	I _C = 500mA, I _B = 50mA	-	-	1.0	V
V _{BE}	V _{CE} = 5V, I _C = 500mA	-	-	1.0	V
f _T	V _{CE} = 5V, I _E = 100mA	-	120	-	MHz
C _{ob}	V _{CB} = 10V, I _E = 0, f = 1MHz	-	-	30	pF

2SC2229 (TR0236)

Absolute Maximum Ratings (Ta=25°C)

SYMBOL	RATINGS	UNIT
V _{CB0}	200	V
V _{CEO}	150	V
V _{EBO}	5	V
I _C	50	mA
I _E	-50	mA
P _C	800	mW
T _j	150	°C
T _{stg}	-55 - 150	°C

ELECTRICAL CHARACTERISTICS (Ta = 25°C)

SYMBOL	CONDITIONS	MIN.	TYP.	MAX.	UNIT
I _{CB0}	V _{CB} = 200V, I _E = 0	-	-	0.1	μA
I _{EBO}	V _{EB} = 5V, I _C = 0	-	-	0.1	μA
h _{FE}	V _{CE} = 6V, I _C = 10mA	70	-	240	
V _{CE(sat)}	I _C = 10mA, I _B = 1mA	-	-	0.5	V
V _{BE(sat)}	I _C = 10mA, I _B = 1mA	-	-	1	V
f _T	V _{CE} = 30V, I _E = -10mA	-	120	-	MHz
C _{ob}	V _{CE} = 10V, I _E = 0, f = 1MHz	-	3.5	5	pF

Silicon Rectifier Diode
S3V40(TD0106)

I_O (A)	V_{RM} (V)	I_{FSM} (A)	P_{RSM} (W)	T_j ($^{\circ}C$)	V_F (V) MAX.	I_R (μA) MAX. at V_{RM}	V_Z (V) MIN.
3.5	400	120	---	+150	1.05	5	---

Zener Diode
WZ-192(TD0065)

ZENER VOLTAGE V_Z (V)			OPERATING RESISTANCE $R_d(\Omega)$		REVERSE CURRENT $I_R(\mu A)$	
MIN.	MAX.	@ I_Z (mA)	MAX.	@ I_Z (mA)	MAX.	@ V_R (V)
18.4	20.1	5	20	5	1	16

Silicon Rectifier Diodes

1N4002/1N4003(TD0002/TD0003)

	1N4002	1N4003	UNIT
Maximum Peak Reverse Voltage	100	200	V
Maximum Input Voltage(RMS)	70	140	V
Maximum DC Reverse Voltage	100	200	V
Maximum Output Current(ave.)	1.0		A
Surge Current	30		A
Maximum Forward Voltage Drop	1.1		V
Maximum Full-Load Reverse Current	30		μA
DC Reverse Current	5.0($25^{\circ}C$), 50.0($75^{\circ}C$)		μA
Reverse Recovery Time	20		μS
Capacitance	15		pF
Thermal Resistance	50		$^{\circ}C/W$
Operating Temperature	-65 ~ +175		$^{\circ}C$
Storage Temperature	-65 ~ +175		$^{\circ}C$

L-3 SPECIFICATIONS

Power Output:	35 watts minimum continuous per channel both channels driven into 8-ohm loads at any frequency from 20Hz to 20,000Hz with no more than 0.04% total harmonic distortion.		
Rated I.M.:	no more than 0.08% (8 ohms, 35W/ch, 60Hz : 7kHz = 4 : 1)		
Frequency Response:	15Hz ~ 60kHz (within -1dB)		
Input Sensitivity & Input Impedance:	PHONO	2.5 mV	50k ohms
	TUNER	145mV	50k ohms
	AUX	145mV	50k ohms
	MONITOR-1	145mV	50k ohms
	MONITOR-2	145mV	50k ohms
Signal-to-Noise Ratio: (input short-circuited)	PHONO	better than 84dB (IHF-A weighted, 10mV)	
	TUNER	better than 90dB (IHF-A weighted)	
	AUX	better than 90dB (IHF-A weighted)	
	MONITOR-1	better than 90dB (IHF-A weighted)	
	MONITOR-2	better than 90dB (IHF-A weighted)	
Residual Noise:	no more than 1mV		
Tone Control:	LUX NF type (100Hz ±11dB, 10kHz ±10dB)		
Filter:	High Cut	7kHz	(-6dB/oct.)
	Subsonic	25Hz	(-6dB/oct.)
Channel Separation:	PHONO	better than 60dB	
	AUX	better than 70dB	
Additional Features:	Tape Monitor (dual), Tape Dubbing (dual), Loudness Control, Mode Selector, Speaker Selector (A, B, A+B, OFF), Extra AC Outlets (SWITCHED, UNSWITCHED), DIN Connector (E-type, S-type only)		
Dimensions:	438(W) x 289(D) x 105(H) (17-1/4" x 11-3/8" x 4-1/8") (including Legs, Rear Protrusions and Knobs)		
Weight:	Net	8.0kgs (17.6 lbs.)	
	Gross	9.5kgs (20.9 lbs.)	

Specifications and appearance design subject to change without notice.

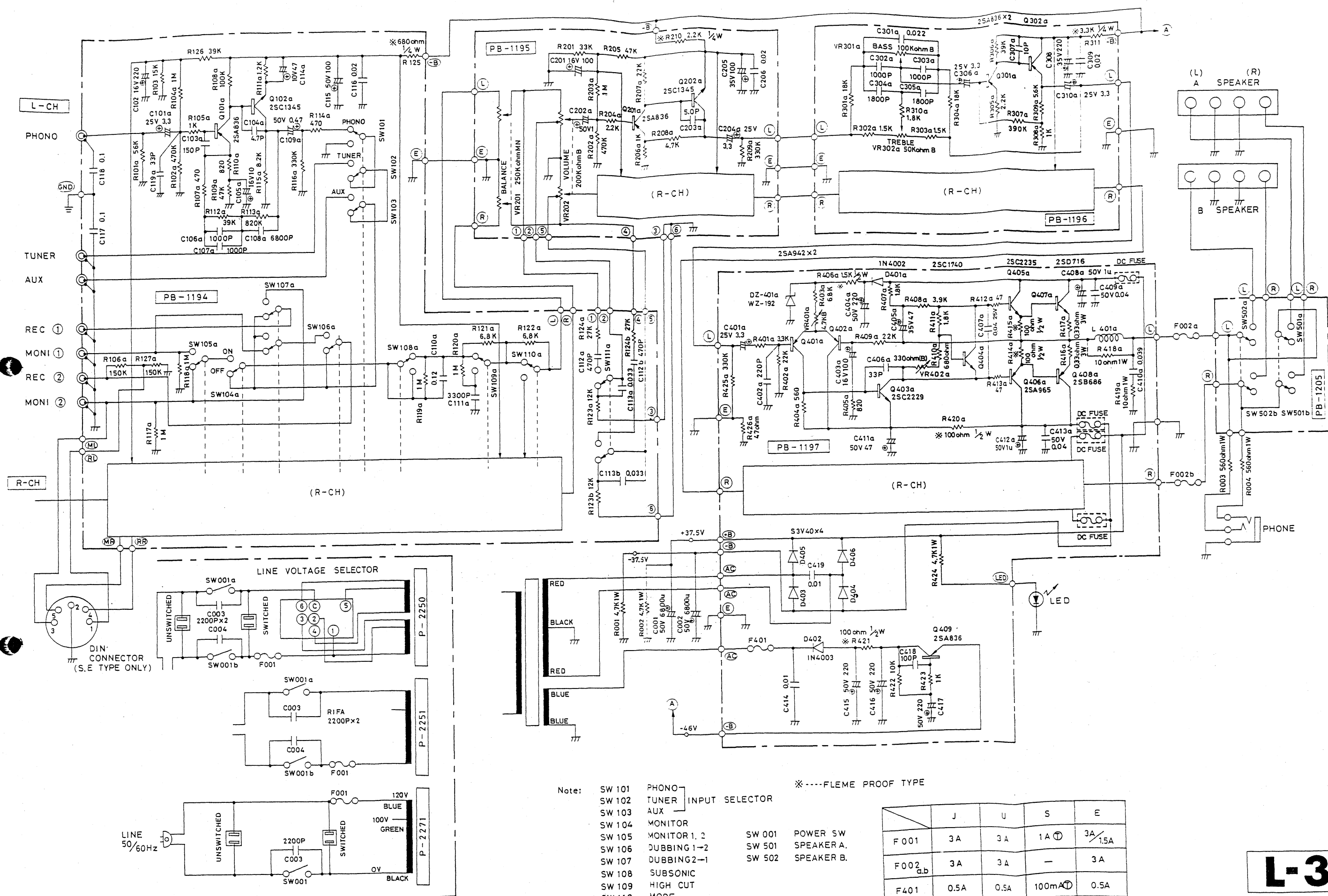

- Note:
- SW 101 PHONO
 - SW 102 TUNER
 - SW 103 AUX
 - SW 104 MONITOR
 - SW 105 MONITOR 1, 2
 - SW 106 DUBBING 1-2
 - SW 107 DUBBING 2-1
 - SW 108 SUBSONIC
 - SW 109 HIGH CUT
 - SW 110 MODE
 - SW 111 LOUDNESS

*----FLEME PROOF TYPE

- SW 001 POWER SW
- SW 501 SPEAKER A.
- SW 502 SPEAKER B.

	J	U	S	E
F 001	3A	3A	1A ⊕	3A / 1.5A
F 002 _{a,b}	3A	3A	—	3A
F 401	0.5A	0.5A	100mA ⊕	0.5A
DC FUSE	—	—	1.6A ⊕	—