

SERVICE MANUAL

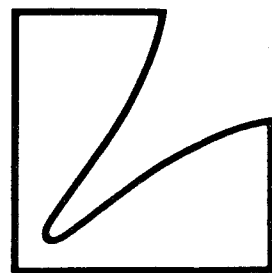

FM/LW/MW
STEREO TUNER **T-210L**

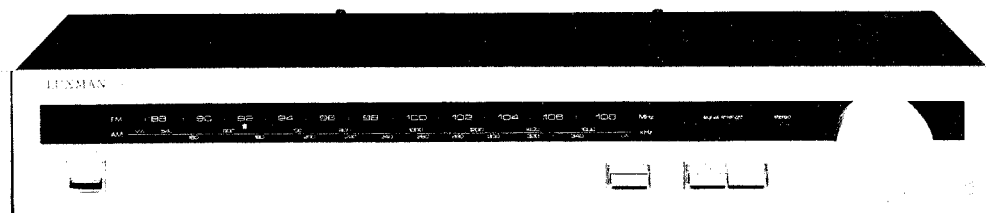

T-210L

CONTENTS

Block Diagram -----	1
Adjustment Locations -----	2
Adjustment Procedure -----	3
Exploded View Parts List -----	4 - 5
Packing Material Parts List -----	6
Power Trans PCB Parts List -----	7
Pointer PCB Parts List -----	7
Radio PCB Parts List -----	8 - 9
LED PCB Parts List -----	10
IC Handling Guide -----	10
Schematic Diagram -----	11-12
Specifications -----	13

Block Diagram

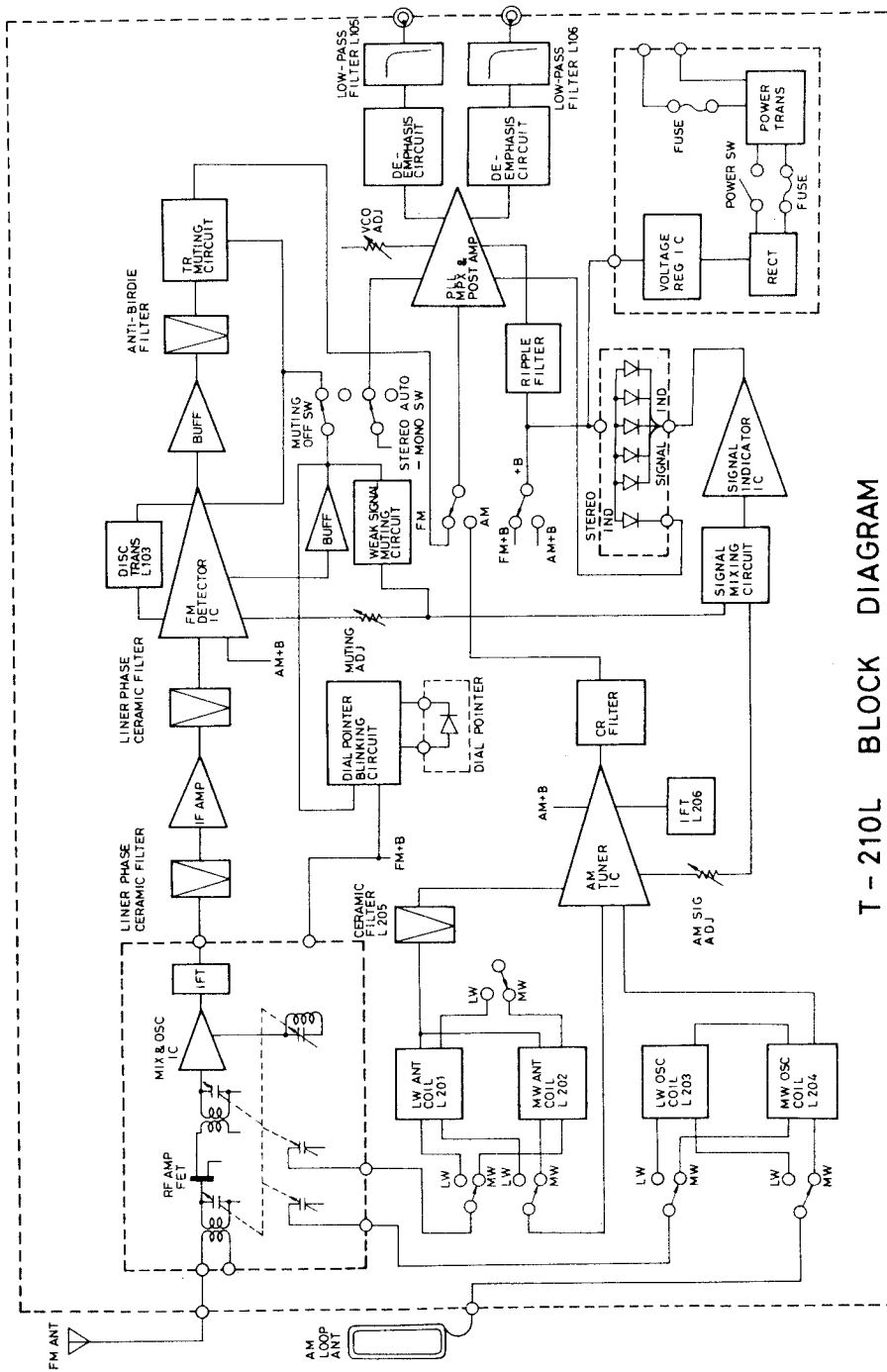

T-210L BLOCK DIAGRAM

Adjustment Locations

SW101:LW/MW
 SW102:AM/FM
 SW103:Mono/Muting
 SW501:Power

L103:FM DET Trans.
 L201:LW OSC Trans.
 L202:MW OSC Trans.
 L203:LW Ant Coil
 L204:MW Ant Coil
 L205:AM IF Trans.
 L206:AM IF Trans.

L-1:IF Core
 T-1:Trimmer
 T-2:Trimmer
 T-3:Trimmer
 T-4:Trimmer

TP-1:Check Pin
 TP-2:Check Pin
 TP-3:Check Pin
 TP-4:Check Pin

VR101:Muting ADJ
 VR102:V.C.O ADJ
 VR201:AM Signal ADJ
 TC201:LW OSC Trimmer
 TC202:LW Ant Trimmer

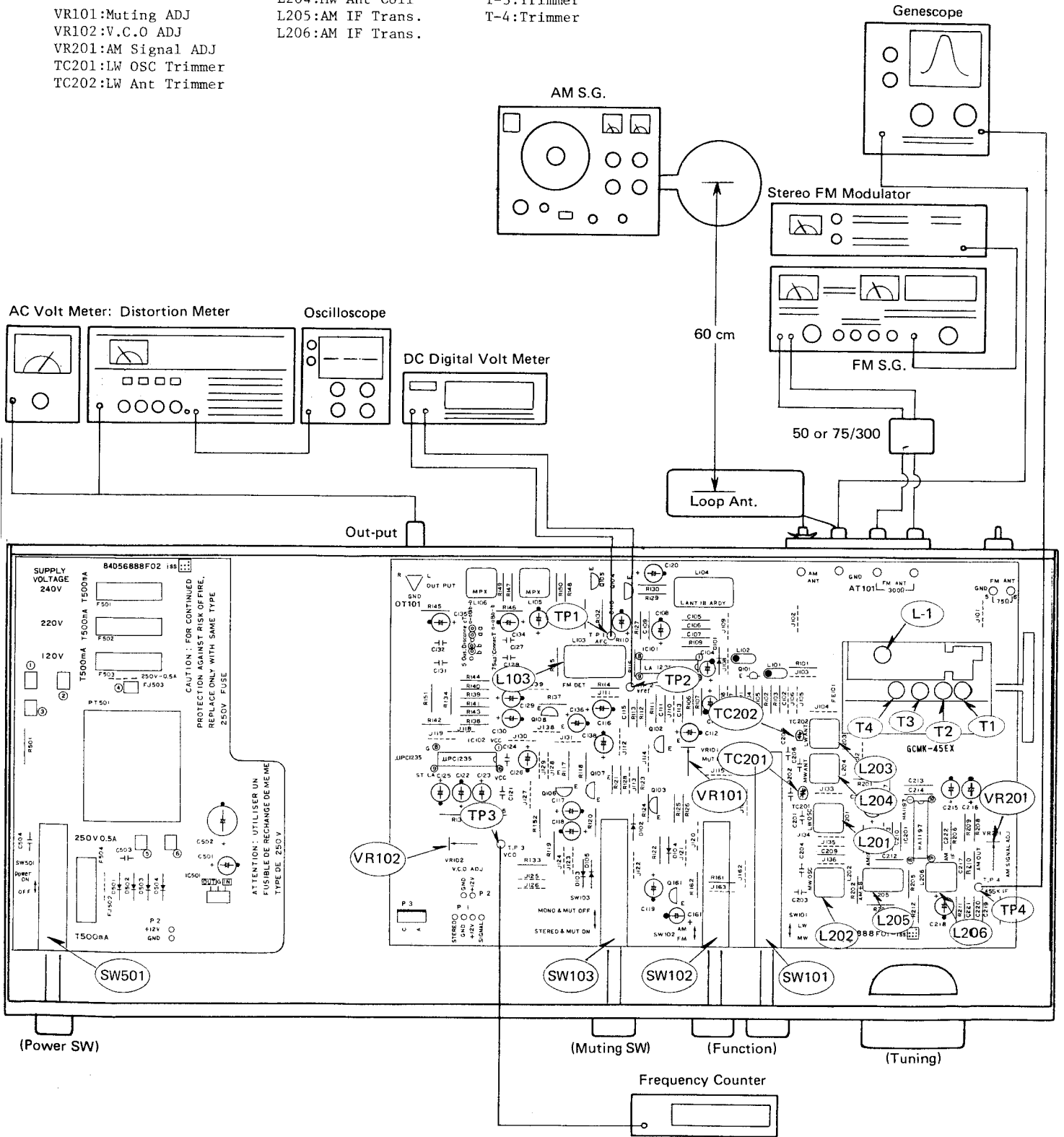

Adjustment Procedure

Step	Signal input connection method	Input signal	Measuring instruments connected	Tuning dial position	Adjustment point	Procedure
1	Set SW103 to Mono/Mut.off, SW102 to FM, SW501 to power off while all other switches are set at any position.					
2	Set each volume of VR101, VR102 and VR201 to center position.					
3	Power on by pressing SW501.					
4			DC digital multi-meter between TP1 & TP2.	At about 98MHz but not at FM station.	Core near to IC101 of L103.	Set DC digital multimeter to +0V. Also ensure blinking of LED dial pointer.
5	FM SG	98MHz at 1KHz 100% modulation output level 65dBf.	Oscill distortion meter, AC voltage meter to output terminals of set.	Exactly at 98MHz.	Core located at opposit side of IC101 of L103.	Adjust to minimize distortion. Repeat 4-5.
6		87.4MHz at 1KHz 100% modulation output level 65dBf.		Low end.		Adjust to set 87.4MHz ^{+100KHz} _{-150KHz}
7		108MHz at 1KHz 100% modulation output level 65dBf.		108MHz	Trimmer of T2 & T4 on front-end.	Adjust to tune exactly at highest sensitivity. Ensure low and high frequency resp. at 87.4MHz+100-108.25MHz+200.
8		98MHz at 1KHz 100% modulation output level 10dBf.		98MHz	IF L-1 core of front-end.	Adjust sensitivity at maximum.
9	Set SW103 to Stereo/Mut.on.					
10	FM SG	98MHz at 1KHz 100% modulation output level 19.0dBf.	Oscill distortion meter, AC voltage meter to output terminals of set.	98MHz	VR101	Adjust VR101 so that output comes out.
11	Ensure the other specifications than FM section.					
12		98MHz output level 60dBf.	Connect frequency counter to TP3.	98MHz	VR102	Adjust to 19KHz+10Hz.
13		98MHz at 19KHz 10% modulation and L-ch or R-ch 90% modulation, output level 65dBf.	Oscill distortion meter, AC voltage meter to output terminals of set.	98MHz	Front-end IF L-1 core.	Maximum adjustment by half turn if distortion exceeds limit. Ensure specs at stereo mode.
14	Set SW102 at AM, and SW101 at MW.					
15	Output of gene-scope to AM ANT terminal.	Center freq. 450KHz Output level 40dB Sweep-speed 5-10Hz	Input of gene-scope to TP-4.	Tune in about 1600KHz having no AM station.	L205 L206	Adjust to get symmetrical wave form and maximum amplitude at 450KHz.
16	AMSG-Loop ant. (Set both loop ant. of set and SG having 60cm distance at their center point in vertical.)	Freq. 600KHz Modulated freq. 400Hz Modulation 30% Output level 58dB/m	Connect synchro-scope, distortion meter and AC volt-meter to output terminal.	Exactly at 600KHz.	L202 L204	Adjust to exactly receive. Adjust so that output becomes maximum.
17		Freq. 1400KHz Mod. freq. 400Hz Modulation 30% Output level 58dB/m		Tune in 1400KHz.	T-1 trimmer in frontend. T-3 trimmer in frontend.	Adjust to exactly receive. Adjust to get maximum output repeating step 16 & 17.
18		Freq. 1000KHz Mod. freq. 400Hz Modulation 30% Output level 80dB/m		Tune in 1000KHz.	VR201	Check if signal LED lights up all (5 segm ents).
19	Check the specifications respectively of MW(Confirm the band edge ranging from 525+15 to 1670+40KHz).					
20	Set SW101 at LW.					
21	AMSG-Loop ant. (Set both loop ant. of set and SG having 60cm distance at their center point in vertical.)	Freq. 170KHz Mod. freq. 400Hz Modulation 30% Output level 68dB/m	Connect synchro-scope, distortion meter and AC volt-meter to output terminal.	Tune in 170KHz (same as 600KHz at MW)	L201 L203	Adjust to exactly receive. Adjust to get maximum output.
22		Freq. 320KHz Mod. freq. 400Hz Modulation 30% Output level 68dB/m		Tune in 320KHz.	TC201(CT201) TC202(CT202)	Adjust to exactly receive. Adjust to get maximum output repeating step 21 & 22.
23	Check the specifications respectively of LW(Confirm the band edge ranging from 150-10 to 350-20KHz).					

T-210L

1000000

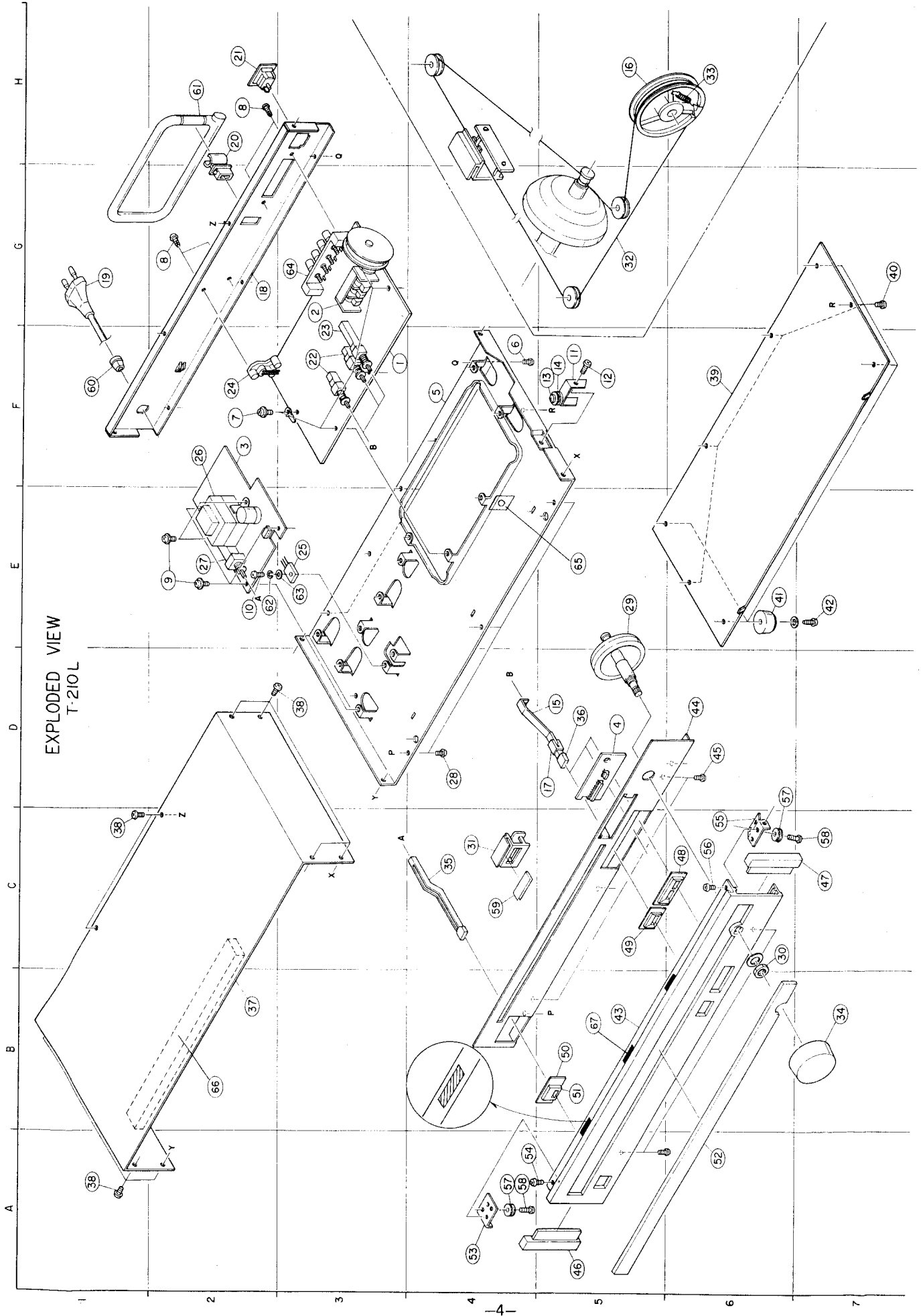

EXPLODED VIEW
T-210L

Exploded View Parts List

Index	Symbol No.	Stock No.	Description	Index	Symbol No.	Stock No.	Description
F-3	1	01V58300F05	Ass'y, Radio PCB (SK)	D-6	57	49A51550F01	Pulley 13
		01V58600F52	Ass'y, Radio PCB (AK)	D-7	58	03B41643U07	Scr, Mch M3x9
		01V59200F46	Ass'y, Radio PCB (UP)	C-4	59	43A56913F01	Spacer, Pointer
G-3	2	77T56895F01	Frontend, F.F711U11X (SK)	F-1	60	43B41625J02	Support Cord
		77T56895F02	Frontend, F.F711E21 (AK)(UP)	H-2	61	85T51078F01	Antenna, Loop
F-2	3	01V58300F06	Ass'y, Power Trans (SK)	E-2	62	04S40071G01	Wash, 3.1x5.9x0.7
		01V58800F13	Ass'y, Power Trans (AK)	E-3	63	04S40070G47	Wash, 3.2x7x0.5
		01V59200F47	Ass'y, Power Trans (UP)	G-3	64	09T51122F01	Terminal, ANT.
D-5	4	01V58300F07	Ass'y, LED PCB	E-6	65	07A57736F01	Bkt, Wheel
F-4	5	27D56857F01	Chas, Main	B-2	66	75A57803F01	Cushion
F-4	6	03S44205G01	Scr, T-Tite M3x6	B-5	67	14S53018F42	Insulator, 50x5
F-2	7	03C42723U01	Scr, Cup M3x6	H-6	33	41A51552F01	Spring, Drum
	8	03S40012G41	Scr, Tpg M3x8	B-7	34	36A56850F01	Knob, Tunig
E-2	9	03C42723U01	Scr, Cup M3x6	C-4	35	36B56851F01	Knob, Push 1194
E-2	10	03S44205G03	Scr, T-Tite M3x8	D-5	36	36A56640F01	Knob, Push 1189
F-5	11	07A56862F01	Bkt, Pulley	B-2	37	15C56855F01	Cover, Top
F-5	12	03S44205G01	Scr, T-Tite M3x6	C-1	38	03S44205G38	Scr, T-Tite M3x6
F-5	13	03B41643J07	Scr, Mch M3x9	F-6	39	15B56856F01	Cover, Bottom
F-5	14	49A51550F01	Pulley 13	G-7	40	03S44205G01	Scr, T-Tite M3x6
D-5	15	45A56864F01	Lever, Knob 1380	E-6	41	75A52969F01	Pad, Tramm-Leg
H-5	16	49A51551F01	Drum, Dial	E-7	42	03S44205G10	Scr, T-Tite M3x10
D-5	17	45B56865F01	Lever, Knob 1223	B-5	43	64C56847F01	Panel, Front
G-2	18	15C56858F01	Cover, Rear (SK)(AK)	D-6	44	07C56859F01	Bkt, Scale
		15C56858F02	Cover, Rear (UP)	D-6	45	03S44205G01	Scr, T-Tite M3x6
G-1	19	28T43812P02	Plug, AC Cord (SK)(AK)	A-5	46	07B56848F01	Frame, Panel Side L
		28T55335F01	Plug, AC Cord SPT-2 (UP)	C-7	47	07B56849F01	Frame, Panel Side R
H-2	20	55T51079F01	Lock, Ant. Holder	C-6	48	07C56907F01	Frame, Knob 1153
H-2	21	09T51080F01	Connector, ANT. (SK)(AK)	C-5	49	07B56852F01	Frame, Knob 1158
F-3	22	40T56893F01	SW, Push SUN 191A2-NS	B-5	50	43A56628F01	Spacer, Power
F-3	23	40T56894F01	SW, Push SUN 191A	B-5	51	61A56641F01	Crystal, Indicator
F-2	24	09T50231F01	Plate, Phone 2P	A-6	52	34B56853F01	Dial, Scale
E-3	25	51T56583F07	IC, Voltage L78N 12V	A-4	53	07A56850F01	Bkt, Side L
F-2	26	25T56902F01	Trans. 82010 (SK)(AK)	A-4	54	03C40014G04	Scr, Mch M3x6
		25T56902F02	Trans. 82014-2 (UP)	C-5	55	07A56861F01	Bkt, Side R
E-2	27	40T56903F01	SW, Power SUF 12	C-6	56	03C40014G04	Scr, Mch M3x6
D-4	28	03S40012G28	Scr, Tpg M3x8	D-6	57	49A51550F01	Pulley 13
E-5	29	49A56863F01	Wheel, Ass'y 1018	D-7	58	03B41643U07	Scr, Mch M3x9
C-6	30	02S4000G20	NUT, HEX M9	C-4	59	43A56913F01	Spacer, Pointer
C-4	31	52B56854F01	Pointer, Scale	F-1	60	43B41625J02	Support Cord
G-5	32	30S43803G06	Dial Cord	H-2	61	85T51078F01	Antenna, Loop
B-5	51	61A56641F01	Crystal, Indicator	E-2	62	04S40071G01	Wash, 3.1x5.9x0.7
A-6	52	34B56853F01	Dial, Scale	E-3	63	04S40070G47	Wash, 3.2x7x0.5
A-4	53	07A56850F01	Bkt, Side L	G-3	64	09T51122F01	Terminal, Ant
A-4	54	03C40014G04	Scr, Mch M3x6	E-6	65	07A57736F01	Bkt, wheel
C-5	55	07A56861F01	Bkt, Side R	B-2	66	75A57803F01	Cushion
C-6	56	03C40014G04	Scr, Mch M3x6	B-5	67	14S53018F42	Insulator, 50x5

Remarks: AK ... 220V for Europe, South East Asia
 (with Line Voltage Selector)
 SK ... 220V for Europe
 UP ... 120V for Canada

Packing Material Parts List

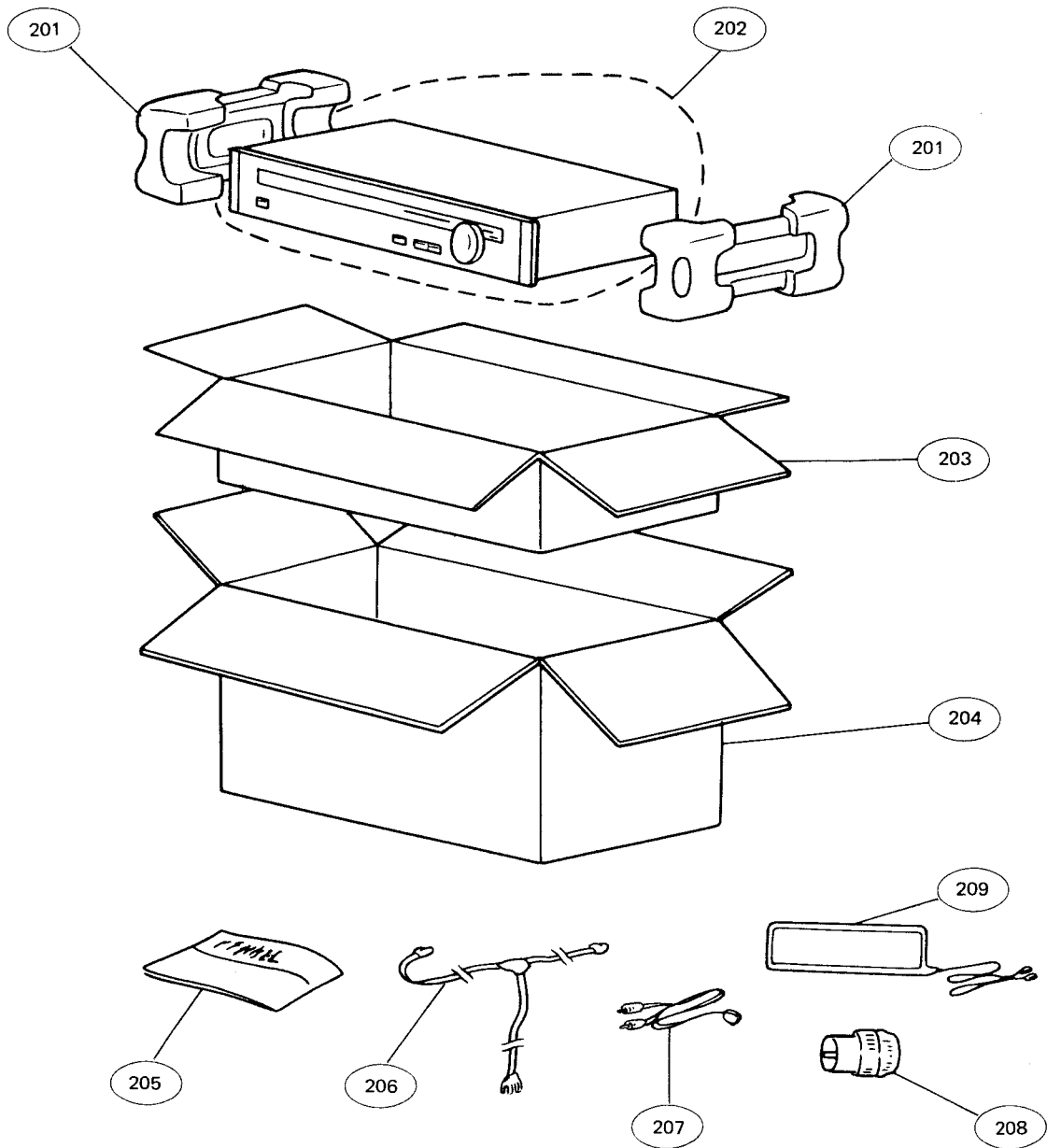

Symbol No.	Stock No.	Description
201	56D56866F01	PKG, Tray
202	56B40230G34	Sack, Poly
203	56C53420F30	Carton, PKG
204	56C53420F31	Carton, PKG
205	ME0250	Owner's Manual
206	85T51069F01	Antenna.FM
207	28C42374J02	Cord Output
208	28T51066F01	Plug, Antenna(SK,AK)
209	85T51078F01	Antenna. Loop

Remarks

Capacitor: El...Electrolytic, Ce...Ceramic, My...Mylar, Pp...Polypropylene
 Resistor : Rd...Carbon, Rm...Metal Film

Power Trans PCB Parts List

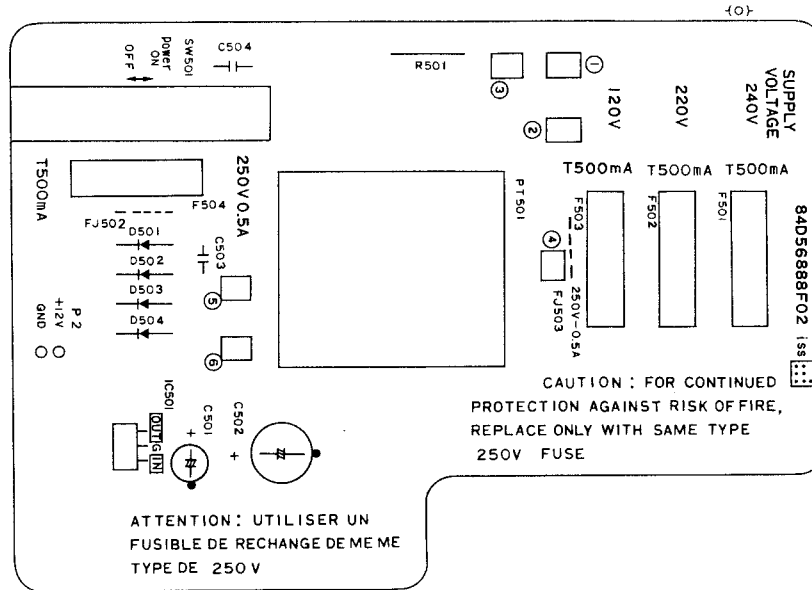

Power Trans PCB Parts List

Symbol No.	Stock No.	Description
(Trans, Power)		
PT501	25T56902F01	No. 82010 (SK) (AK)
	25T56902F02	No. 82014-2 (UP)
(Holder, Fuse)		
F501	09T51410F01	Holder, Fuse (AK)
F502	09T51410F01	Holder, Fuse (SK) (AK)
F503	09T51410F01	Holder, Fuse (AK)
	09T51960F01	YSH-401T (UP)
F504	09T51410F01	Holder, Fuse (SK) (AK)
	09T51960F01	YSH-401T (UP)
(Fuse)		
F501	65T42077U13	T-500mA (240V-AK)
F502	65T42077U13	T-500mA (220V-SK.AK)
F503	65T42077U13	T-500mA (120V-AK)
	65T52486F31	CS61M 0.5A-250V(UP)
F504	65T42077U13	T-500mA (SK) (AK)
	65T52486F31	CS61M 0.5A-250V(UP)

Symbol No.	Stock No.	Description
(Switch)		
SW501	40T56903F01	SUF12
(IC)		
IC501	51T56583F07	L78N 12V
(Diode)		
D501	48T55186F01	GP10D
D502	48T55186F01	GP10D
D503	48T55186F01	GP10D
D504	48T55186F01	GP10D
(Capacitor)		
C501	23T51235F16	10uF 16V E1
C502	23T51234F78	1000uF 25V E1
C504	21C45322G32	22000pF 50V Ce
(Resistor)		
R501	06D40802G44	2.2M 1/2W Rd (UP)

Pointer PCB Parts List



Pointer PCB Parts List

Symbol No.	Stock No.	Description
(Diode)		
D401	48T56899F01	SLB-26UR5

T-210

Radio PCB Parts List

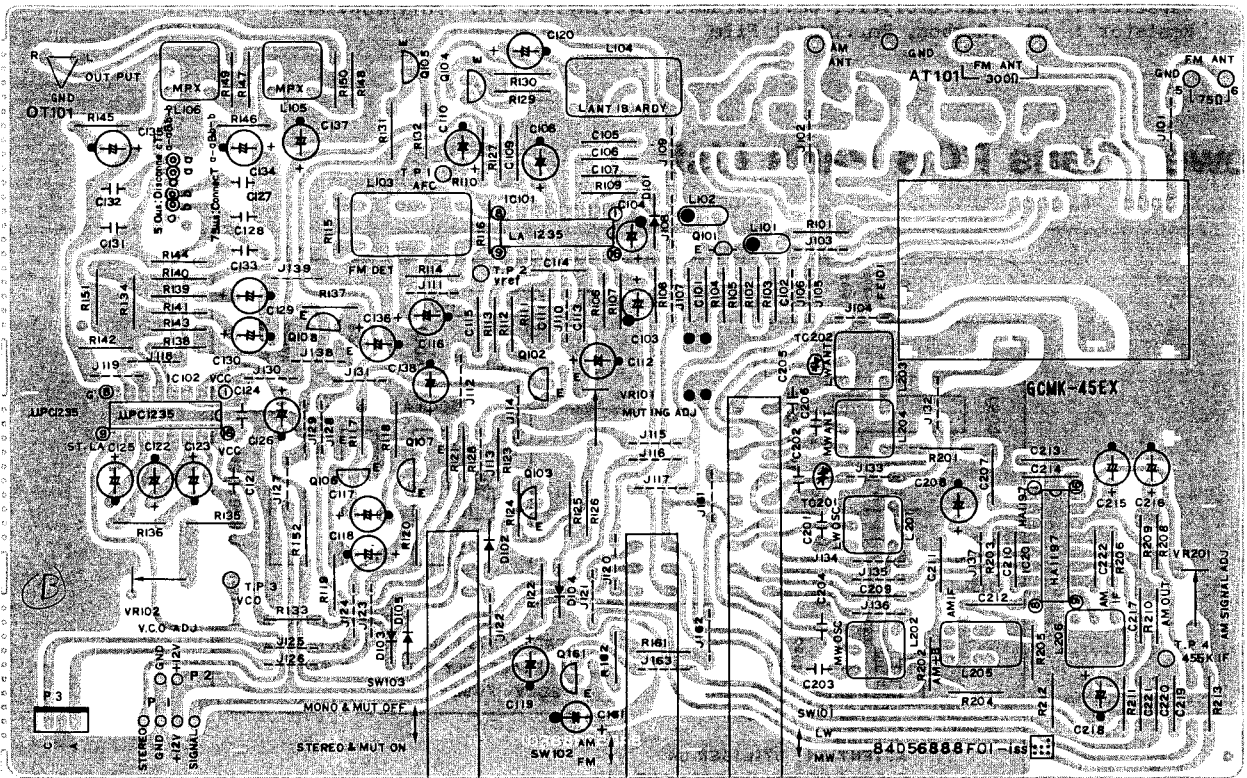

Symbol No.	Stock No.	Description
(Switch)		
SW101	40T56894F01	SUN 191A
SW102	40T56893F01	SUN 191A2-NS
SW103	40T56893F01	SUN 191A2-NS
(Front, End)		
FE101	77T56895F01	F.F 711U11X (SK)
	77T56895F02	F.F 711E21 (UP) (AK)
(Terminal)		
AT101	09T51122F01	Terminal, Ant.
(Plate, Phone)		
OT101	09T50231F01	Plate, Phone 2P
(Variable Resistor)		
VR101	18C42061J13	5K
VR102	18C42061J13	5K
VR201	18C42061J13	5K
(Trimmer)		
TC201	20T47503F02	TZ03 (Red)
TC202	20T47503F02	TZ03 (Red)
(Coil & Filter)		
L101	91T51130F01	Filter, Cer SFE10.7MM
L102	91T51130F01	Filter, Cer SFE10.7MM
L103	24T51128F01	FM DET LA1457
L104	91T51083F01	Filter, Anti Birdy
L105	91T51124F01	Filter, MPX LA1209
L106	91T51124F01	Filter, MPX LA1209
L201	24T56891F01	LW OSC
L202	24T51542F01	AM LUX-1073
L203	24T56892F01	LW, ANT.
L204	24T51125F01	ANT. (AM)
L205	24T51126F01	IF (455KHz)
L206	24T53327F01	IF, Trans.

Symbol No.	Stock No.	Description	
(IC)			
IC101	51T51095F01	LA1235	
IC102	51T51094F01	UPC1235	
IC201	51T56890F01	HA1197	
(Transistor)			
Q101	48S44580J03	2SC1675K	
Q102	48S43525F02	2SC1815Y	
Q103	48S43525F02	2SC1815Y	
Q104	48S43525F02	2SC1815Y	
Q105	48S43525F02	2SC1815Y	
Q106	48S43525F02	2SC1815Y	
Q107	48S43525F02	2SC1815Y	
Q108	48S43525F02	2SC1815Y	
Q161	48S43525F02	2SC1815Y	
(Diode)			
D101	48T51582F01	MA-150	
D102	48T51582F01	MA-150	
D103	48T51582F01	MA-150	
D104	48T51582F01	MA-150	
D105	48T51582F01	MA-150	
(Capacitor)			
C101	08S44505P63	22000pF	Ce
C102	08S44505P63	22000pF	Ce
C103	23T51235F01	0.47uF	50V E1
C104	23T51235F16	10uF	16V E1
C105	08S44505P63	22000pF	Ce
C106	08S44505P62	22000pF	Ce
C107	08S44505P63	22000pF	Ce
C108	23T51235F24	22uF	16V E1
C109	08S44505P37	100pF	Ce
C110	23T51235F03	1uF	50V E1

Symbol No.	Stock No.	Description	
C111	08S44505P63	22000pF	Ce
C112	23T51235F13	4.7uF	50V E1
C113	08S44505P63	22000pF	Ce
C114	08S44505P63	22000pF	Ce
C115	08S44505P63	22000pF	Ce
C116	23T51235F44	100uF	16V E1
C117	23T51235F03	1uF	50V E1
C118	23T51235F03	1uF	50V E1
C119	23T51235F05	2.2uF	50V E1
C120	23T51235F16	10uF	16V E1
C121	08T52448F05	0.00047uF	Pp
C122	23T51235F03	1uF	50V E1
C123	23T51235F08	3.3uF	50V E1
C124	08S40656F21	0.047uF	My
C125	23T42478F20	0.22uF (LN)	50V E1
C126	23T51235F16	10uF	16V E1
C127	08T52448F07	0.00056uF	Pp
C128	08T52448F13	0.0010uF	Pp (SK) (AK)
	08T52448F18	0.0016uF	Pp (UP)
C129	23T51235F24	22uF	16V E1
C130	23T51235F24	22uF	16V E1
C131	08T52448F13	0.0010uF	Pp (SK) (AK)
	08T52448F18	0.0016	Pp (UP)
C132	08T52448F07	0.00056uF	Pp
C133	08T52448F05	0.00047uF	Pp
C134	23T51235F03	1uF	50V E1
C135	23T51235F03	1uF	50V E1
C136	23T51235F38	47uF	16V E1
C137	23T51235F44	100uF	16V E1
C138	23T51235F44	100uF	16V E1
C161	23T51235F08	3.3uF	50V E1
C162	08S40805F21	22000pF	Ce
C201	08T42081U05	150p	Pp
C202	21S40655F21	68pF	Ce
C203	08T52448F03	0.00039uF	Pp
C204	21S40655F15	22pF	Ce
C205	21S40655F17	33pF	Ce
C206	21S40655F13	15pF	Ce
C207	08S44505P63	22000pF	Ce
C208	23T51235F44	100uF	16V E1
C209	08S44505P63	22000pF	Ce
C210	08S44505P63	22000pF	Ce
C211	08S44505P63	22000pF	Ce
C212	08S44505P63	22000pF	Ce
C213	08S44505P63	22000pF	Ce
C214	08S44505P63	22000pF	Ce
C215	23T51235F03	1uF	50V E1
C216	23T51235F05	2.2uF	50V E1
C217	08S44505P63	22000pF	Ce
C218	23T51235F38	47uF	16V E1
C219	08S44505P53	2200pF	Ce
C220	08S44505P63	22000pF	Ce
C222	08S44505P49	1000pF	Ce
(Resistor)			
R101	06S44593P41	100	1/4W Rd
R102	06S44593P75	2.7K	1/4W Rd
R103	06S44593P57	470	1/4W Rd
R104	06S44593P53	330	1/4W Rd
R105	06S44593P53	330	1/4W Rd
R106	06S44593P89	10K	1/4W Rd
R107	06S44594P12	82K	1/4W Rd
R108	06S44594P06	47K	1/4W Rd

Symbol No.	Stock No.	Description	
R109	06S44593P53	330	1/4W Rd
R110	06S44593P89	10K	1/4W Rd
R111	06S44594P06	47K	1/4W Rd
R112	06S44593P65	1K	1/4W Rd
R113	06S44593P33	47	1/4W Rd (SK,AK)
	06S40150T33	47	1/4W Rd (UP)
R114	06S44593P83	5.6K	1/4W Rd
R115	06S44593P73	2.2K	1/4W Rd
R116	06S44593P83	5.6K	1/4W Rd
R117	06S44593P81	4.7K	1/4W Rd
R118	06S44594P18	150K	1/4W Rd
R119	06S44594P12	82K	1/4W Rd
R120	06S44593P89	10K	1/4W Rd
R121	06S44593P69	1.5K	1/4W Rd
R122	06S44593P81	4.7K	1/4W Rd
R123	06S44593P81	4.7K	1/4W Rd
R124	06S44593P89	10K	1/4W Rd
R125	06S44594P06	47K	1/4W Rd
R126	06S44594P06	47K	1/4W Rd
R127	06S44593P41	100	1/4W Rd
R128	06S44594P06	47K	1/4W Rd
R129	06S44593P73	2.2K	1/4W Rd
R130	06S44593P89	10K	1/4W Rd
R131	06S44593P89	10K	1/4W Rd
R132	06S44593P89	10K	1/4W Rd
R133	06S44593P89	10K	1/4W Rd
R134	06S44594P34	680K	1/4W Rd
R135	06S44593P93	15K	1/4W Rd
R136	06S44593P65	1K	1/4W Rd
R137	06S44593P77	3.3K	1/4W Rd
R138	06S44593P97	22K	1/4W Rd
R139	06S44593P83	5.6K	1/4W Rd
R140	06S44594P06	47K	1/4W Rd
R141	06S44593P83	5.6K	1/4W Rd
R142	06S44594P06	47K	1/4W Rd
R143	06S44593P97	22K	1/4W Rd
R144	06S44593P41	100	1/4W Rd
R145	06S44593P77	3.3K	1/4W Rd
R146	06S44593P77	3.3K	1/4W Rd
R147	06S44593P77	3.3K	1/4W Rd
R148	06S44593P77	3.3K	1/4W Rd
R149	06S44593P41	100	1/4W Rd
R150	06S44593P41	100	1/4W Rd
R151	06S44594P06	47K	1/4W Rd
R152	06S44594P04	39K	1/4W Rd
R161	06S44593P41	100	1/4W Rd
R162	06S44593P97	22K	1/4W Rd
R201	06S44593P41	100	1/4W Rd
R202	06S44593P45	150	1/4W Rd
R203	06S44593P73	2.2K	1/4W Rd
R204	06S44593P89	10K	1/4W Rd
R205	06S44593P83	5.6K	1/4W Rd
R206	06S44593P53	330	1/4W Rd
R208	06S44593P89	10K	1/4W Rd
R209	06S44593P89	10K	1/4W Rd
R210	06S44593P99	27K	1/4W Rd
R211	06S44593P41	100	1/4W Rd
R212	06S44593P93	15K	1/4W Rd
R213	06S44593P89	10K	1/4W Rd

LED PCB Parts List

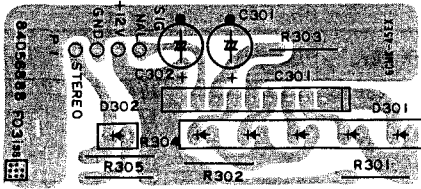

LED PCB Parts List

Symbol No.	Stock No.	Description
(IC)		
IC301	51T51086F01	BA 6125
(Diode)		
D301	48T56898F01	SLJ-265 UR 5HL
D302	48T56899F01	SLB-26UR5
(Capacitor)		
C301	23T51235F16	10uF 16V E1
C302	23T51235F16	10uF 16V E1
(Resistor)		
R301	06S44593P41	100 1/4W Rd
R302	06S44593P41	100 1/4W Rd
R303	06S44593P89	10K 1/4W Rd
R304	06S44593P89	10K 1/4W Rd
R305	06S44593P67	1.2K 1/4W Rd

IC Handling Guide

HA1197 (AM Tuner System)

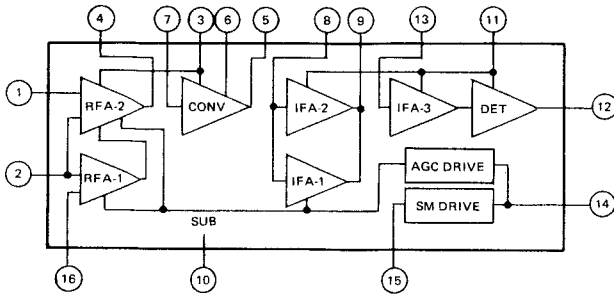

LA1235 (FM IF System)

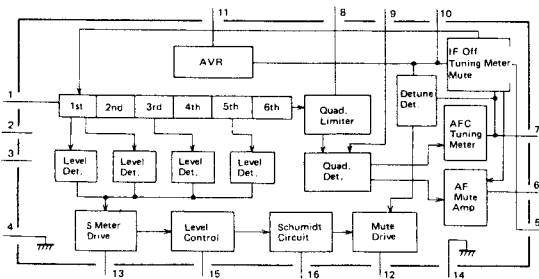

BA6125 (LED Linear Level Meter Driver)

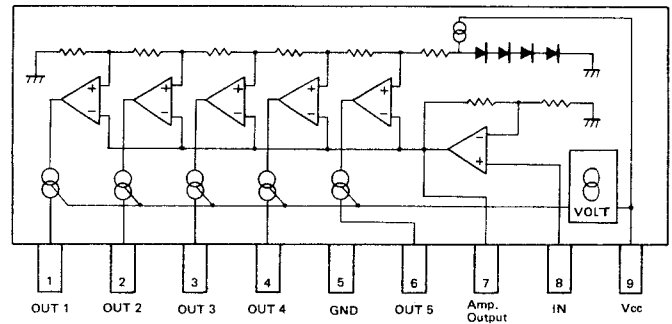

UPC1235C (FM Stereo Demodulator)

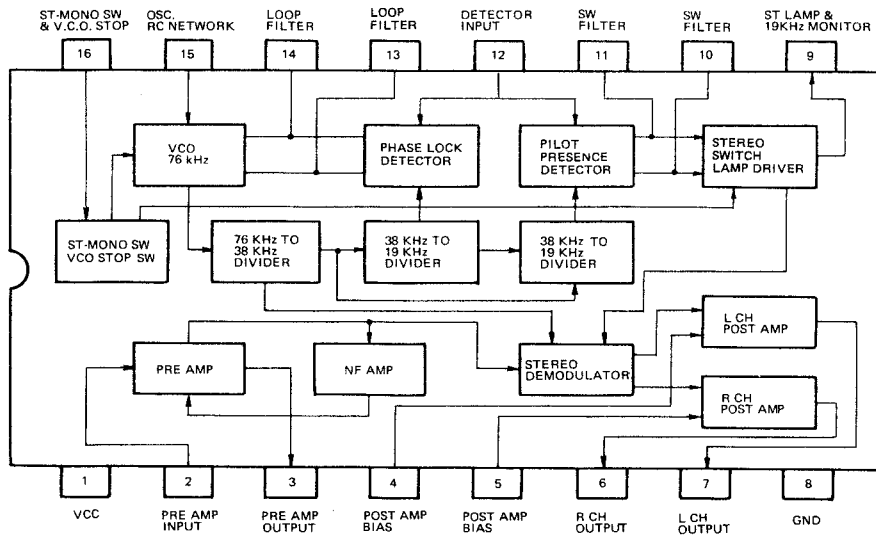

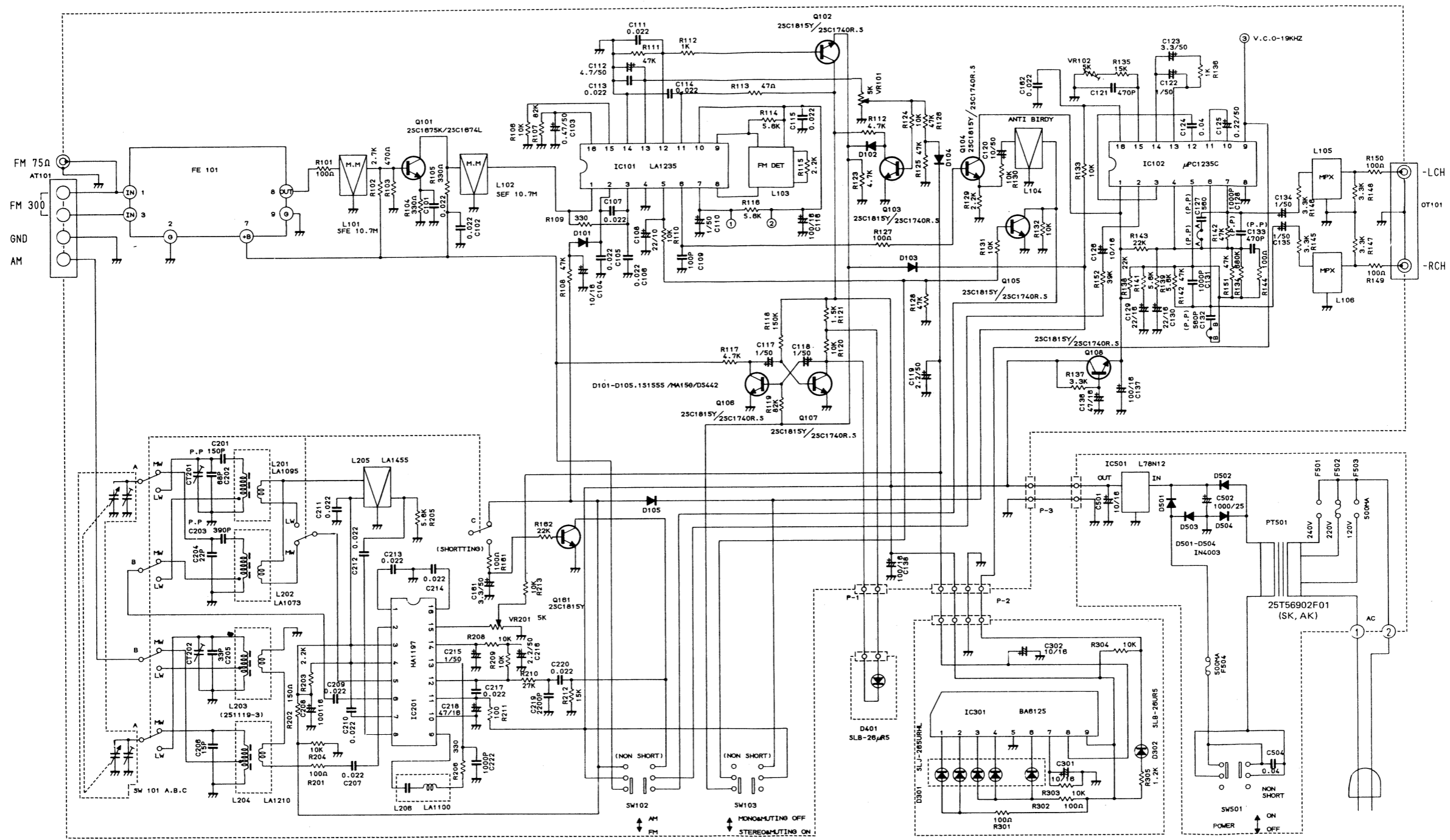

NOTE

- | | |
|--------------|--|
| 1 SW SETTING | •SW501 POWER SW -ON |
| | •SW101 MW/LW -LW |
| | •SW102 AM/FM -FM |
| | •SW103 STEREO & MUTE/MONO -STEREO & MUTE |
| 2 NOTE | •Q101 2SC1675K/2SC1674L |
| | •Q102-108 2SC1815Y/2SC1740R.5 |

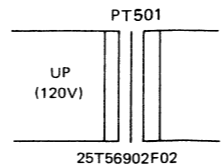

Remarks

1. Unless otherwise specified, all resistors are in ohm 1/4 watt, all capacitors are in micro farad.
2. Transistors, IC and diode, may be replaced with any types having comparable rating.
3. Due to continued improvement LUX reserve the right to alter the circuit or specification.



Specifications

[FM Section]

Usable Sensitivity 75 ohms/300 ohms:		0.95uV/1.9uV(10.8dBf)
50 dB Quieting Sensitivity 75 ohms/300 ohms:		1.75uV/3.5uV(16.0dBf)
S/N Ratio at 65 dBf mono/stereo:		75dB/72dB
Frequency Response:		30Hz-15KHz (-1dB)
Distortion at 65 dBf:	mono 100Hz	0.15%
	1KHz	0.15%
	6KHz	0.3%
	stereo 100Hz	0.25%
	1KHz	0.2%
	6KHz	0.3%
Capture Ratio at 65 dBf:		1.5dB
Alternate Channel Selectivity	75KHz deviation:	65dB (+400KHz)
	40KHz deviation:	55dB (+300KHz)
Spurious Response Ratio:		80dB
IF Response Ratio:		90dB
Image Response Ratio:		45dB
AM Suppression Ratio:		55dB
Stereo Separation:	100Hz	30dB
	1KHz	40dB
	10KHz	30dB
Muting Threshold:		5uV
Output Level: 100% MOD.		700mV

[AM Section]

	MW	LW
Usable Sensitivity:	58dB/m	66dB/m
Image Response Ratio:	45dB	43dB
IF Response Ratio:	36dB	32dB
Distortion:	0.6%	1.3%
S/N Ratio:	45dB	40dB
Output Level:	220mV	200mV

[General]

Power Consumption:	7W
Dimensions:	453(W)x244(D)x77(H)mm
	(17.8"x9.6"x3.0")
Weight:	Net 2.8kgs(6.2lbs.)
	Gross 3.5kgs(7.7lbs.)

Specifications and appearance design subject to change without notice.