

---

# C-383

Stereo Preampfier

---

OWNER'S MANUAL  
BEDIENUNGSANLEITUNG  
MODE D'EMPLOI  
MANUAL DE OPERACIÓN  
LIBRETTO DELLE ISTRUZIONI

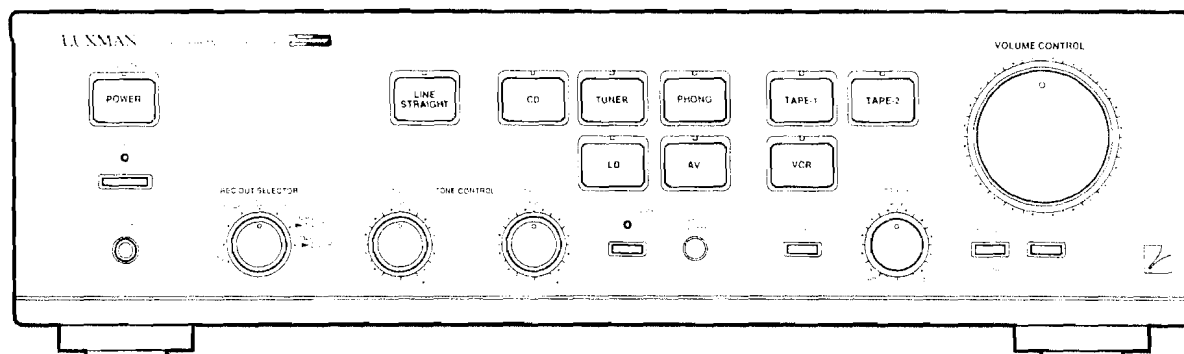



Reference Illustrations .....	4
Introduction .....	6
Connection Guidelines .....	7
Names & Functions of Parts .....	8
Operation Guidelines .....	12
Care and Maintenance .....	15
In case of Difficulty .....	16
Specifications .....	17

Abbildungen .....	4
Vor der Inbetriebnahme .....	18
Anschluß .....	19
Bezeichnung der Teile und Funktionen .....	20
Bedienung .....	24
Wartung und Pflege .....	27
Im Störfall .....	28
Technische Daten .....	29

Illustrations de Référence .....	4
Introduction .....	30
Directives de Branchement .....	31
Nomenclature .....	32
Directives de Fonctionnement .....	36
Soin et Entretien .....	39
En cas de problèmes .....	40
Spécifications .....	41

Ilustraciones de referencia .....	4
Introducción .....	42
Guías para las conexiones .....	43
Nomenclatura funciones de las partes .....	44
Guías para la operación .....	48
Cuidados y mantenimiento .....	51
En caso de dificultad .....	52
Especificaciones .....	53

Illustrazioni di riferimento .....	4
Introduzione .....	54
Istruzioni sul collegamento .....	55
Nomenclatura e funzioni delle parti .....	56
Informazioni sul funzionamento .....	60
Cura e manutenzione .....	63
In caso di problemi .....	64
Dati Tecnici .....	65

English

Deutsch

Français

Español

Italiano

Fig. 1/Abb. 1/III. 1

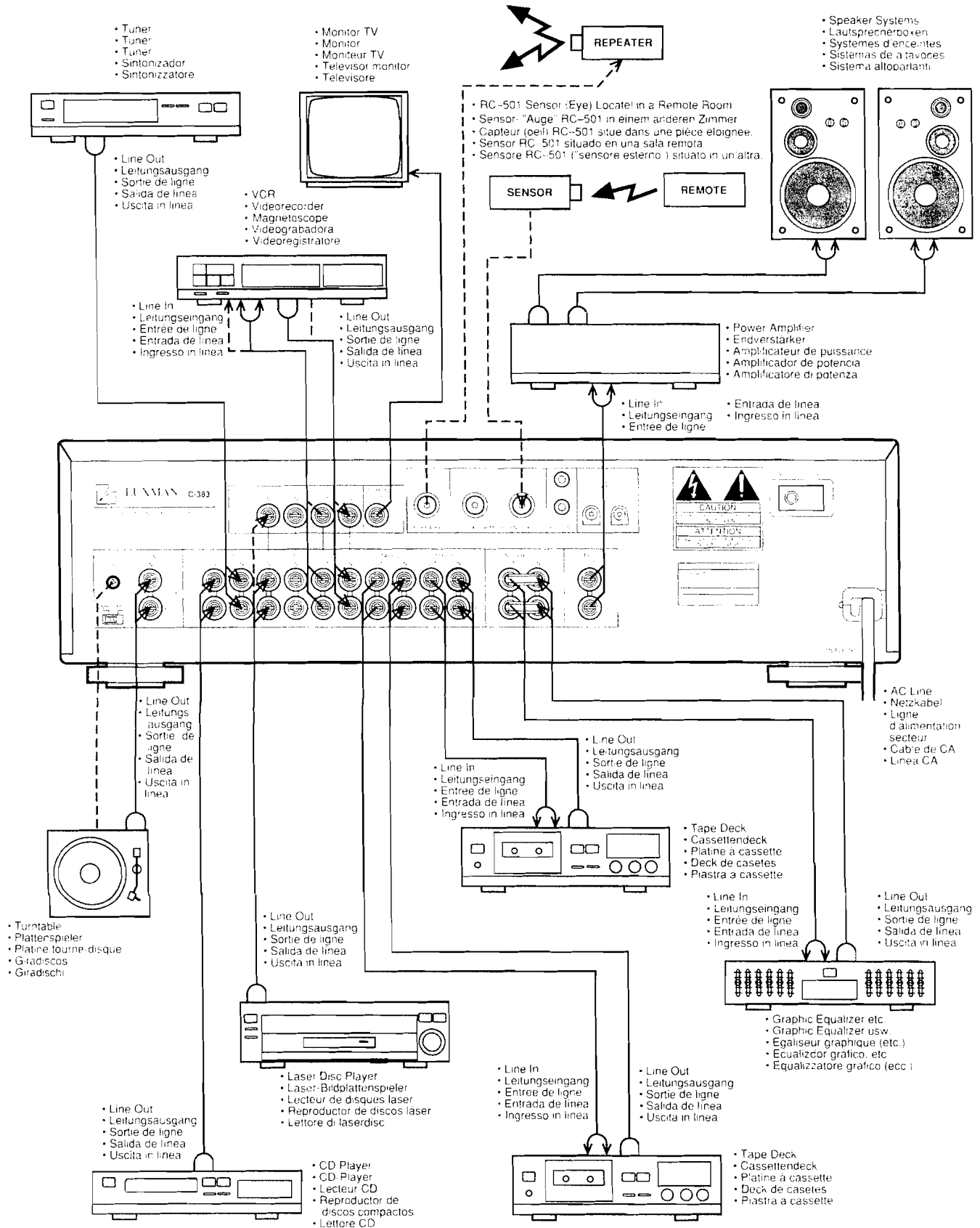

Fig. 2/Abb. 2/III. 2

- System "BUS" and AC cord connections for "BUS" operation. Illustration shows a typical combination example.
- "BUS LINE"-Systemanschlüsse und Netzanschlüsse für den "BUS"-Systembetrieb. Die Abbildung zeigt ein typisches Kombinationsbeispiel.
- Branchements du système "BUS" et du cordon d'alimentation secteur pour une utilisation "BUS". L'illustration indique un exemple de combinaison caractéristique.
- Conexiones del sistema "BUS" y de los cables de alimentación de CA para la operación del sistema "BUS". En la ilustración se muestra un ejemplo de combinación típico.
- Collegamenti del sistema "BUS" e del cavo di alimentazione per l'operazione "BUS". L'illustrazione mostra un esempio di combinazione tipica.

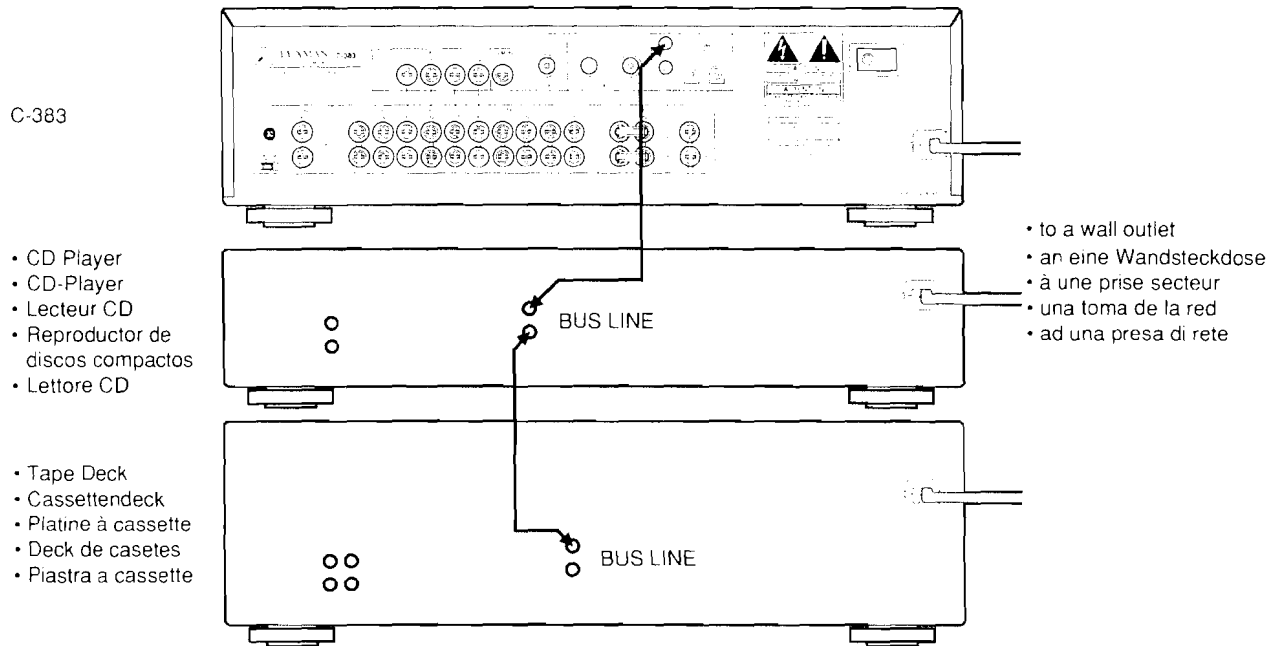

Fig. 3/Abb. 3/III. 3

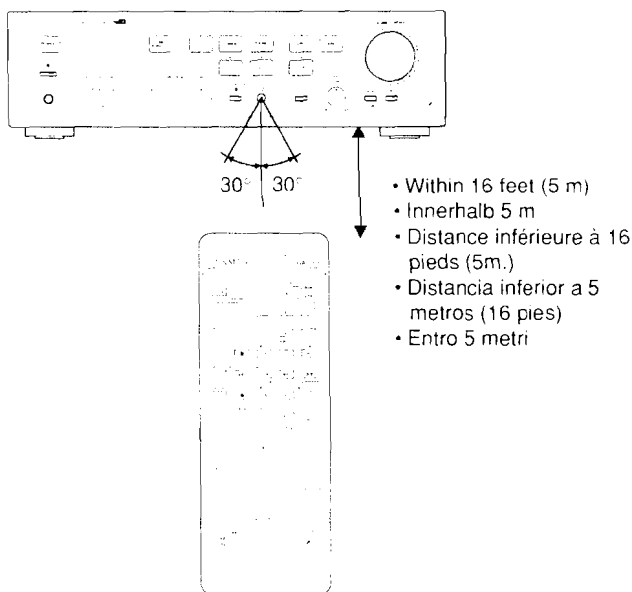
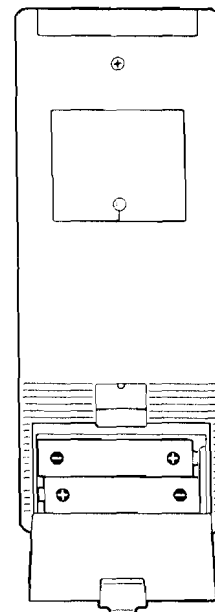

Fig. 4/Abb. 4/III.4



English

Deutsch

Français

Español

Italiano

## **Welcome!**

*At Luxman, Ultimate Fidelity is a goal we consider most important. Your purchase of this component has told us you feel the same. We take great pride in the long tradition of excellence in sonic quality that the Luxman name represents. Now, as part of that tradition, we welcome you to the growing number of discerning audiophiles who own and operate Luxman products. This manual has been prepared to help you maximize your enjoyment of the outstanding performance and feature capabilities of your new Luxman C-383.*

*This stereo preamplifier represents a novel concept in system and design technology for simplified system operation and high sonic quality. It has System Bus, multi-room capability, full system remote control, motor driven volume control, Video Input/Output jacks and LINE straight ... are some of the items that combine to achieve this goal.*

*To realize the exceptional performance for which this Preamplifier is capable, it is necessary that all signal sources, power amplifier and speaker systems used with it are of the highest sonic quality. We recommend complementary Luxman components wherever possible.*

*Please study this manual carefully and become acquainted with all the special features, operation and capabilities of your new Luxman C-383. Should you have any questions or desire information on other Luxman products, please contact your local Luxman dealer.*

## **When You Open the Box**

Before any Luxman product leaves the factory it is carefully inspected for physical imperfections as a routine part of Luxman's systematic quality control. This, along with full electrical testing, should insure quality craftsmanship and performance. After you have unpacked the unit, inspect it for any physical damage. Save the shipping carton and all packing materials, as they are essential to reduce to a minimum the possibility of transportation damage. Should the product ever need to be shipped again. In the unlikely event that damage has occurred, notify your dealer immediately and request the name of the carrier so that a written claim to cover shipping damages can be initiated.

---

**The right to any claim against a public carrier can be forfeited if the carrier is not notified promptly and if the shipping carton and packing material are not available for inspection. Save all packing materials until the claim has been settled.**

---

## **Installation and Placement**

The Luxman C-383 generates almost no heat, therefore its placement is not critical. However it should not be placed on top of or completely enclosed with high power amplifier. If placed in a cabinet with such components, be sure adequate ventilation is provided. With these considerations implemented, the Luxman C-383 should provide exceptional performance in any reasonable environment.

Of course, such normal considerations as protection from excessive dust and moisture should always be observed. The Luxman C-383 Preamplifier has been carefully designed with high quality components so that long term undiminished performance may be expected when it is operated in accordance with the instructions provided.

## Before Making Connections

It is always wise to ensure that all AC power cords of the various components that you are interconnecting are unplugged from the wall outlets during the hook-up process. This will prevent any inadvertent damage to your speakers or amplifier from incorrect control settings or connections.

## Interconnecting Leads

Be sure that left and right channel identification is correct when making interconnections. Most patch cords are colour coded with RED ends for the right channel and BLACK or WHITE ends for the left channel, to make this job easier.

In addition, all jacks on the rear of the C-383 have red centres for right channel and white for left channel. When making connections, follow the Reference Illustration on page 4, referring also to the descriptions for items #27 through #45 on pages 10 and 11.

## Power Amplifier Connections

Connect the "PRE OUT" jacks of the C-383 to the Input jacks of your power amplifier with phono type patch cords.

If the Luxman power amplifier M-363 or M-383 is used with the C-383, connect it to the "TO POWER AMP" jack on the rear panel of the C-383. Refer to the owner's manual of the power amplifier for details.

## Note on the Signal Processor Jacks

- Keep the jumper bars inserted when the "SIGNAL PROCESSOR" jacks are not in use. If the jumper bars are removed, there will be no sound output.
- Remove the jumper bars only when connecting a graphic equalizer or signal processor to the "SIGNAL PROCESSOR" jacks.

## AC Power Cord

Insert the AC plug of the C-383 into an appropriate wall outlet.

## SYSTEM REMOTE JACK CONNECTIONS

### Bus Line Jack

- To control "SYSTEM BUS" equipped models (such as a Luxman D-373 CD player and a K-373 tape deck) connect them to this jack. Connect the audio

leads of the tape deck to the Tape-1 inputs and place the "TAPE-1/TAPE-2" switch on the back panel of the tape deck to the Tape-1 position.

- For remote operation of two BUS equipped tape decks, you may connect the audio leads of one to the Tape-1 inputs and the other to the Tape-2 inputs. Place the "TAPE-1/TAPE-2" switch on the back panel of the first deck to Tape-1 position and the second to Tape-2. The two decks can then be selected by the Tape-1/Tape-2 switch on the C-383 (item #5) or the RA-383 remote control (item #19).
- When interconnecting source units, the mini phone cables may be inserted into either jack (the control signals are bidirectional, therefore no "IN OUT" protocol is required).
- Plug the AC power cords of each unit included in the "BUS" system into wall AC outlets.
- "SYSTEM BUS," identified by the symbol  printed on the carton and owner's manual of the unit, indicates the Luxman models that work with the "BUS LINE" jacks on the rear panel.

## EXT REMOTE SENSOR In Jacks

These 2 jacks may be connected directly to Luxman RC-501 Infrared Remote Sensor "eyes," located in other rooms, via standard coaxial cable (RG-6 is recommended). This allows all remote functions to be controlled from other rooms as desired, or, in the same room if the C-383 is placed behind closed cabinet doors.

Up to six RC-501s may be connected to the C-383 if a DC pass 3-way splitter (such as PHILMORE CS14) is used at each sensor input.

## Repeater Output Jack

This repeater jack may be connected directly to a Luxman RC-503 IR repeater unit, also via standard coaxial cable. Remote control of non Luxman units, such as a VCR, may then take place through the C-383 remote system.

---

### Note:

Place the C-383 so that its remote sensor will not receive the signals transmitted from the RC-503.

---

## Front Panel

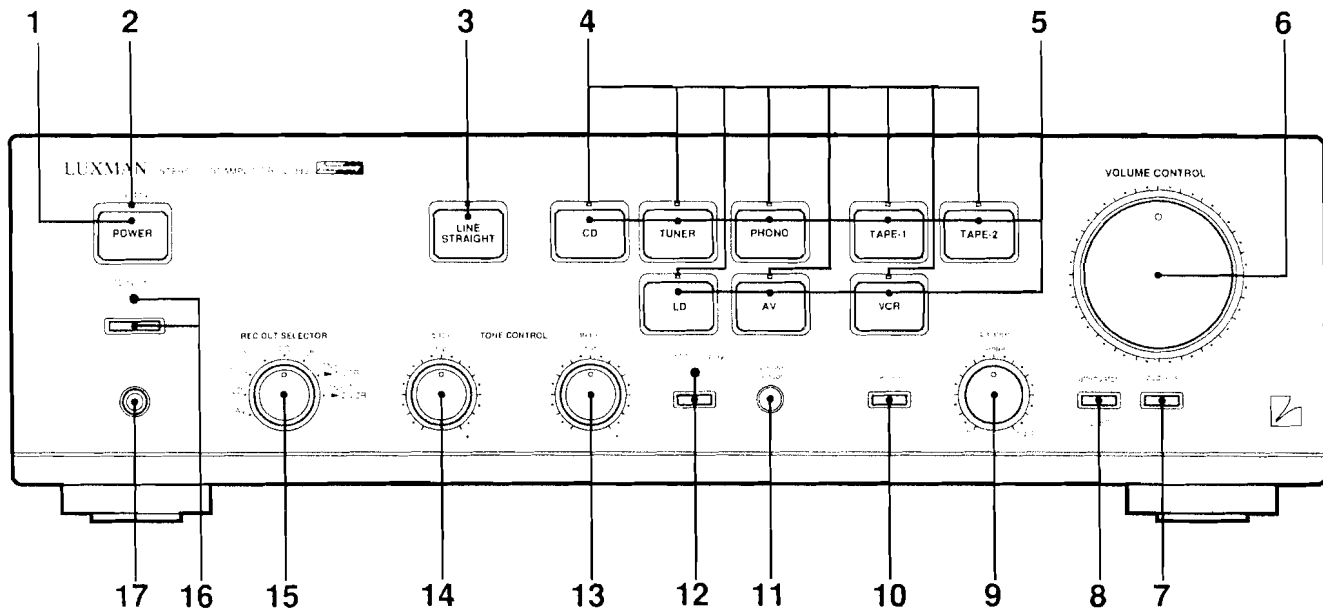

### 1. "POWER" button

Pressing this button turns the unit on and off. When this button is depressed, the time delay muting circuit is turned on, putting the amplifier into perfect operational condition in about 5 seconds.

### 2. "stand-by" indicator

This indicator shows that the unit is ready to receive remote control commands and will stay lit at all times as long as the power cord is plugged in.

### 3. "LINE STRAIGHT" button and indicator

Press this button to bypass control and switching functions.

### 4. Input Select indicators

The LED indicator for the selected input source will light up to tell which source is selected with the Input Select buttons (item #5).

### 5. Input Select buttons

Press one of these buttons to select any one of eight sources: CD, TUNER, PHONO, TAPE-1, TAPE-2, LD, AV and VCR.

### 6. "VOLUME CONTROL"

Allows precision, low noise adjustment of volume level. It is recommended that the volume control be set to a low position prior to power turn on and when switching between sources.

### 7. "loudness" button

Depressing this button introduces a moderate boost of the very low and high frequencies when the volume control is set below the half-way position. This compensates for the human ear's characteristic at low listening levels.

### 8. "attenuator" button

Press this button to reduce the volume level to 1/10 of the current level.

### 9. "balance" control

Adjusts for unequal volume level between channels. Normally, with today's high quality sources, it is seldom necessary to move this control from its precision centre detent position.

### 10. "mono" button

Place in the mono (in) position for mono sources, for balance control adjustment, for lower noise operation from high noise stereo source, or for checking speaker phasing. Otherwise, leave it in the stereo (out) position.

### 11. "remote sensor"

When using the hand held remote control, it must be pointed toward this sensor to activate operational functions.



## 12. "Continuous play" button and indicator

When this button is depressed during cassette or CD play, the cassette deck or CD player will continue to operate even when the Input Selector is switched. However, you can hear the sound of the selected source with the Input Selector.

## 13. "treble" control

This control will increase or decrease high frequency content in the program material. At the centre detent position, a flat frequency response results.

## 14. "bass" control

This control will increase or decrease low frequency content in the program material. At the centre detent position, a flat frequency response results.

## 15. "REC OUT SELECTOR" switch

This 8 position rotary switch selects any one of 5 sources, AV, LD, phono, tuner and CD, to be fed to the "REC OUT" jacks of both tape 1 and tape 2 for recording purpose. And two tape dubbing positions, tape-1▶2/VCR and tape-2▶1/VCR, are also selectable. All of these recording operations can be performed independently of any selected source that you may wish to listen to at the same time.

Set it to the off position, when recordings or dubs are not being made.

## 16. "CD synchro" button and indicator

CD play and tape recording can be started simultaneously by simply pressing the "CD synchro" button. In addition the LED indicator will blink.

### Notes:

- CD Synchro only works with a BUS connected system.
- The "REC OUT SELECTOR" switch (item #15) must be in the "CD" position.

## 17. "phones" jack

Connection of stereophonic headphones to this jack allows private listening. There is signal at the jack at all times.

## Remote Control Unit (RA-383)

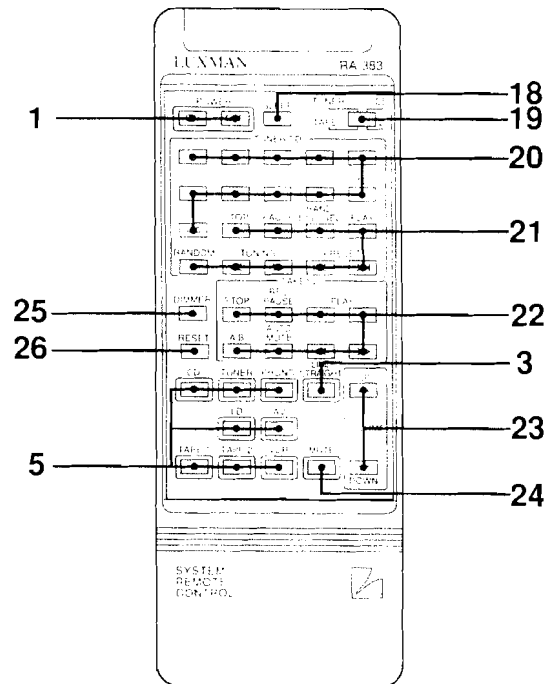

## 18. "SLEEP" button

## 19. "TUNER CD/TAPE-1 TAPE-2" Select switch

## 20. "TUNER" Station Presets/"CD" Direct Access buttons (1 - 10 and +10)

## 21. CD/TUNER Control buttons

## 22. Tape Deck Control buttons

## 23. "VOLUME UP/DOWN" buttons

## 24. "MUTE" button

## 25. "DIMMER" button

## 26. "RESET" (dimmer) button

## Rear Panel

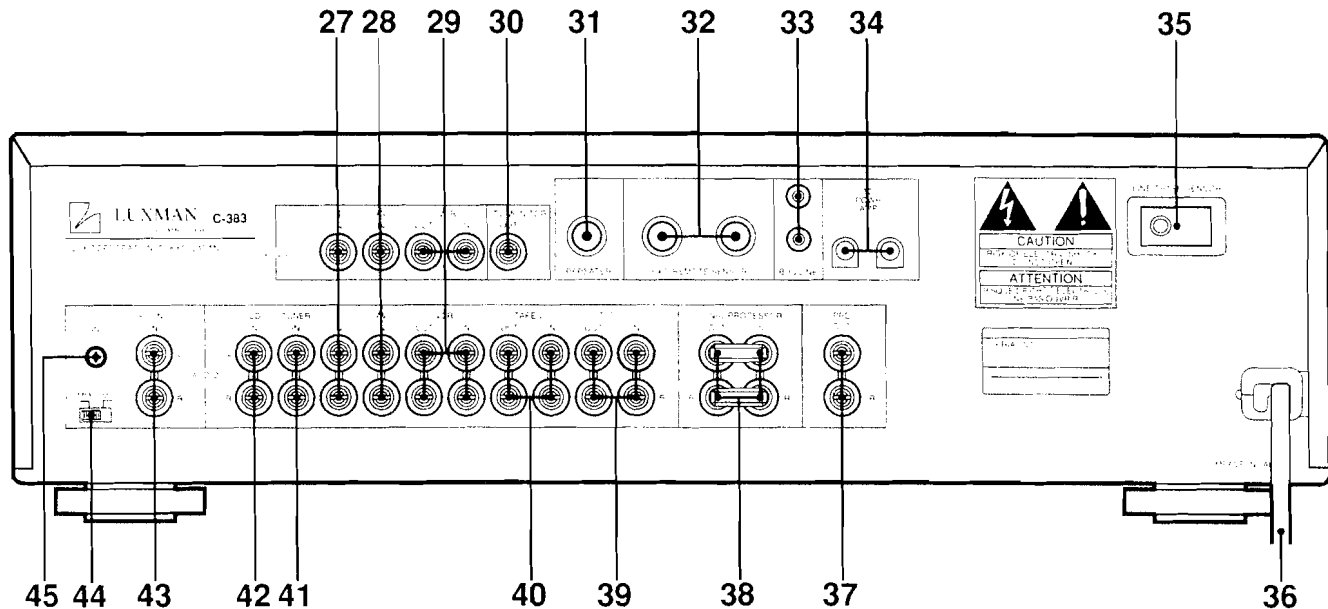

### 27. "LD (AUDIO/VIDEO)" Input jacks

Connect the video and audio output terminals of a laser disc player to these jacks.

#### Note:

See Reference Illustrations, page 4, for typical connections to all jacks and terminals (items #27 through 45).

### 28. "AV (AUDIO/VIDEO)" Input jacks

Connect the video and audio output terminals of a video deck or laser disc player to these jacks.

### 29. "VCR IN and OUT (AUDIO/VIDEO)" jacks

Connect the video and audio output/input terminals of a video deck to the VCR IN/OUT jacks on the C-383 respectively.

### 30. "TV MONITOR OUT" jack

Connect the video input jack of a TV to the "TV MONITOR OUT" jack of the C-383.

### 31. "REPEATER" jack

For connection of Luxman's remote control command repeater, RC-503.

### 32. "EXT. REMOTE SENSOR IN" jacks

These "F" type coaxial connectors are for connection of Luxman's RC-501 remote room sensor "eyes." This permits remote control of a complete C-383 system from other rooms.

### 33. Remote Control "BUS LINE" jacks

Use these jacks only with Luxman CD players, Tape Decks and Tuners that are also equipped with BUS line jacks, such as the D-373 and the K-373.

When interconnecting these units with the C-383, the mini phone cables may be inserted into either of their two BUS jacks (the control signals are bidirectional, therefore no "IN OUT" protocol is required).

### 34. "TO POWER AMP" jack

When the Luxman power amplifier M-383 or M-363 is connected to this jack, the power amplifier can be turned on or off simultaneously with the C-383.

**35. "LINE PHASE SENSOR" indicator**

When plugging the AC power cord into the wall outlet, check the polarity of the AC power cord at this sensor and indicator. When the sensor is touched after connecting the AC power cord, the polarity is correct if the indicator remains unlit. If the indicator lights up, unplug the AC power cord then plug its other side into the AC wall outlet.

---

**Note:**

Check the polarity before connecting any sources. If you live in an apartment building where the power supply is floating, the indicator may not change status.

---

**36. AC Power Cord**

Insert the AC plug of the C-383 into an appropriate wall outlet.

**37. "PRE OUT" jacks**

Use these jacks for connection of a power amplifier.

**38. "SIGNAL PROCESSOR IN and OUT" jacks**

For connection of a surround sound processor, an equalizer or other signal processor as desired.

---

**Note:**

Jumper bars are factory installed in these jacks. They need to be removed only when connecting a processor. Retain for possible future reuse.

---

**39. "TAPE-1 IN and OUT" jacks**

Connect the LINE IN and LINE OUT jacks of your audio tape deck to these OUT and IN jacks respectively.

**40. "TAPE-2 IN and OUT" jacks**

Connect a 2nd tape deck to these jacks in the same manner as item #39 above.

**41. "TUNER IN" jacks**

This set of jacks is for connection of a tuner. They may also be used for any other high level signal source as well.

**42. "CD IN" jacks**

This set of jacks is for connection of a CD (compact disc) player. They may also be used for any other high level signal source as well.

**43. "PHONO IN" jacks**

Connect a phono turntable equipped with an MM (moving magnet) or MC (moving coil) cartridge. Set the MM/MC cartridge select switch (item #44) in the matching position.

**44. "MM/MC" Cartridge Select switch**

Use this switch to match with the cartridge type connected to the C-383's PHONO IN jacks.

**45. "GND" terminal**

Connect the common (ground) lead of your phono turntable to this terminal.

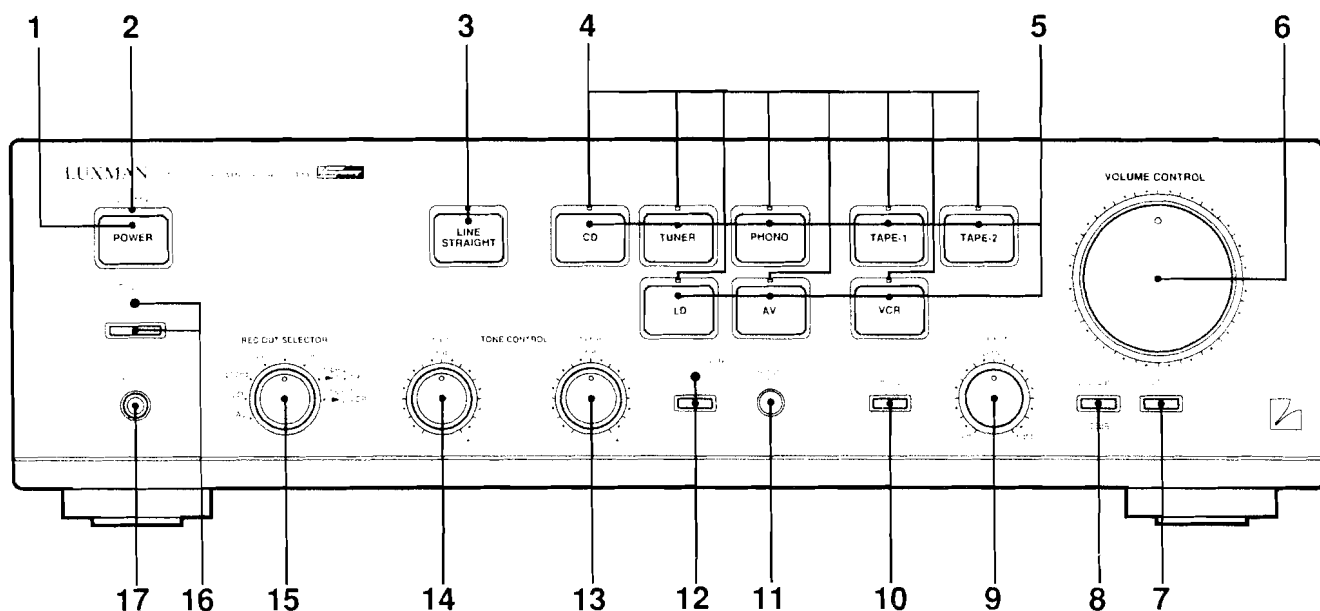

The following guidelines assume that all connections have been made according to the "Reference Illustrations," page 4.

### Power and Source Switching

To prevent the possibility of excessive, sudden sound levels, it is recommended that the volume control be placed at a low level position each time the power button is turned on or when switching between sources by the INPUT SELECTORS.

### To Play Source Units

1. Turn the power on to all the components in use.
2. Choose your desired source with the Input Selector buttons (item #5).
3. Operate the source unit.

## TAPE DECK OPERATIONS

### Tape Recording Operations

To make a tape recording of any source, proceed as follows:

1. Rotate the "REC OUT SELECTOR" (item #15) to the source you wish to record.
2. The source signal will now be fed to the tape deck. Follow the recording instructions for the tape deck in use.
3. If you have a 3 head deck, you can monitor the actual recording by depressing the corresponding "TAPE-1" or "TAPE-2" buttons (item #5) on the C-383.

### Video Recording

To make a video tape recording of any video source, proceed as follows:

1. Rotate the "REC OUT SELECTOR, (item #15) to the source you wish to record (LD or AV).
2. The source signal will now be fed to the connected VCR. Follow the recording instructions for the VCR in use.

### Tape Dubbing

Tape copies can be made from TAPE-1 to TAPE-2/ VCR or from TAPE-2 to TAPE-1/VCR as follows:

1. To dub from TAPE-1 to TAPE-2/VCR, rotate the "REC OUT SELECTOR" (item #15) to the tape-1►2/VCR dubbing position.
2. Place tape deck 1 in the PLAY mode and deck 2 in the RECORD mode.
3. If audio tape deck 2 is a 3 head machine, actual monitoring of the audio recording can take place by selecting "tape-2" on the Input Select button (item #5).
4. Similarly, to dub from TAPE-2 to TAPE-1/VCR, rotate the "REC OUT SELECTOR" to the tape-2►1/VCR dubbing position.
5. Follow steps (2) and (3) above except remember decks 1 and 2 are reversed.

## Remote Control Operation

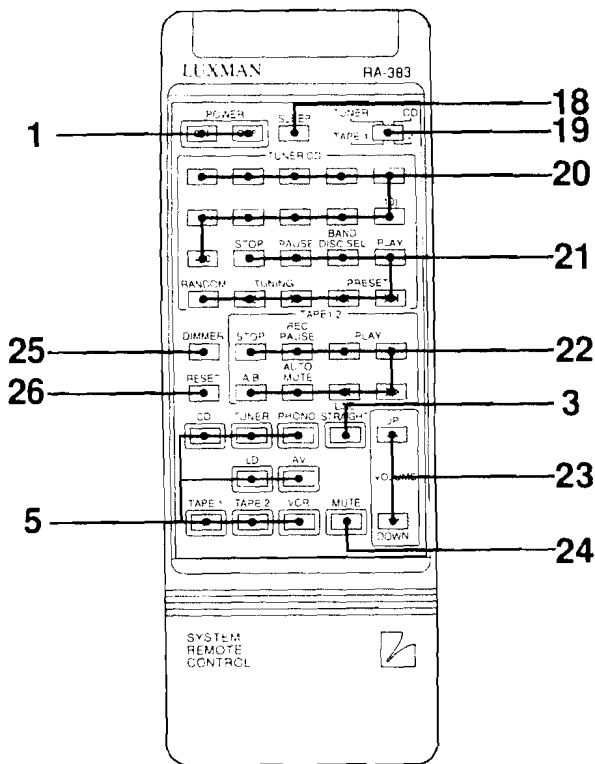

### To Turn Power ON or OFF

Press "POWER ON/OFF" buttons (item #1).

### Operating the C-383

- To select a desired source, press a source button (item #5), CD, TUNER, PHONO, LD, AV, TAPE-1, TAPE-2 and VCR.
- To turn up the volume, press "VOLUME UP" button (item #23).
- To turn down the volume, press "VOLUME DOWN" button (item #23).
- To mute the sound temporarily, press "MUTE" button (item #24).
- To restore the sound, press it again. (During muting, the volume indicator blinks.)

## BUS SYSTEM OPERATIONS

Products connected to the "BUS LINE" jack allow following operations from the RA-383 remote control unit.

## Automatic Source Switching and Play of Music Sources

When a source button on the RA-383 is pressed, the corresponding source unit will automatically be placed in the PLAY mode and be heard. Similarly, when a play button is pressed on a source unit or the tuning or station preset buttons pressed on the tuner, the input source selector on the C-383 will automatically be switched to the corresponding source. This feature works only with Luxman CD players, Tuner and Tape Decks that are equipped with BUS line jacks.

### Operating the Cassette Deck

The operations in the following table are possible for either one or two "SYSTEM BUS" decks connected to the "TAPE-1" and "TAPE-2" jacks. Choose the desired deck with the "TAPE-1/TAPE-2" selector (item #19).

To start playback	>
To start reverse playback	<
To fast forward to the right/rewind to the right	>>
To fast-forward to the left/rewind to the left	<<
To music search to the right • Each time a >> or << button is pressed, a track is added. (Up to 8 tracks in both directions.)	> or < ↓ >>
To music search to the left • Each time a >> or << button is pressed, a track is added. (Up to 8 tracks in both directions.)	> or < ↓ <<
To select deck A or B	A/B
To stop playback or recording	STOP
To set the cassette deck to recording pause mode	REC PAUSE
To record • Press the < or > button, use direction that is the same as that indicated by the tape direction indicator on the tape deck.	REC PAUSE ↓ < or >

### Note:

Location of the switches will be different depending upon the models connected, so perform operations by referring to the Owner's Manual for each model.

## Operating a CD Player

The following operations are possible.  
Set the "TUNER CD" switch to the CD position.

To start play	PLAY
To stop play	STOP
To stop play temporarily	PAUSE
To skip tracks in forward direction	>>
To skip tracks in backward direction	<<<
To search a track in forward direction	>>
To search a track in backward direction	<<
To select a disc in a CD changer	DISC SEL ↓  << >>

### Note:

Location of the switches will be different depending upon the models connected, so perform operations by referring to the Owner's Manual for each model.

## "CD Synchro" Recording

When the C-383 is used with BUS line equipped source units, such as the Luxman D-373 CD player and K-373 cassette tape deck, synchronized start/record, pause and stop functions are possible when making recordings of CDs with the press of a single button. For instance, when the "CD synchro" button (item #16) on the C-383 is pressed, the K-373 cassette deck will go into record mode and the D-373 begins playing at the same time.

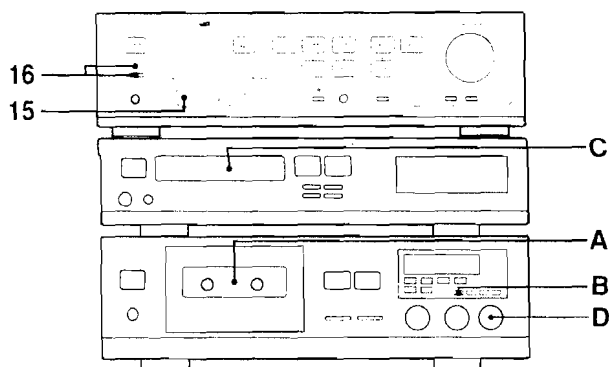

Use the following procedure:

1. Set the "REC OUT SELECTOR" (item #15) to "CD."
2. Insert a tape for recording into the deck (item #A in a previous diagram).

3. Select the Dolby NR mode with the "DOLBY NR" switch (item #B).

	DOLBY NR ON/OFF button	B/C button
To record in Dolby B NR mode	■ ON (depressed)	■ B (released)
To record in Dolby C NR mode	■ ON (depressed)	■ C (depressed)
To record without Dolby NR mode	■ OFF (released)	Any position

4. Place the disc in the CD player (item #C). Recordings can be made to fit the length of the tape used, if your CD player has an editing function. For further details, refer to the manual of the CD player.
5. Turn "REC LEVEL" control (item #D) to rec and adjust the recording level.
6. Press "CD synchro" button (item #16) of the C-383. CD play and tape recording will start simultaneously. The recording level is indicated by the level indicator. When +3 lights up on music peaks, the level is set appropriately.
7. To stop synchronized recording, press the STOP button on the cassette deck or CD player.

### Notes:

- CD Synchro recording can only be performed using the tape deck connected to the "TAPE-1" jacks on the C-383.
- Be sure to advance past the leader tape before recording. Otherwise, the beginning of the CD may not be recorded.
- Location of the switches will be different depending upon the models connected, so perform operations by referring to the Owner's Manual for each model.
- To record on both sides using an auto-reverse deck, start with the front side. Recording cannot be continued from the reverse side to the front side. Therefore, when the recording on the reverse side is completed, it stops.
- Recording will not start if the playback button for the opposite direction is pressed when using an auto-reverse deck.

### How to Use Sleep Timer

When a tuner with the sleep timer function is connected to the system control, timer operations are available. The power can be cut off automatically after 90 – 10 minutes. Setting step is 10 minutes.

1. Push the "SLEEP" button (item #18) during playback.
2. Set a desired time by repeatedly pushing the "SLEEP" button. The time will be changed by 10 minutes step each time the button is pushed.

With the tuner used, various timer playback can be made. For further details, refer to the manual for the tuner.

### Remote Operations

For reliable operation, use the hand-held remote control within the basic dimensional area shown on page 5, Fig. 3.

### Cleaning

The durable finish of the knobs and front panel will last indefinitely with proper care and cleaning. Never use scouring pads, steel wool, scouring powders, or harsh chemical agents, such as lye solution. These will mar the finish. Clean with a soft, lint-free cloth or cotton swab slightly dampened with a mild solution of detergent and water.

### Repacking for Shipment

Should it become necessary to ship your C-383 for any reason, use the original packing materials. If these are no longer available, be sure that adequate materials, at least equivalent to the original, are used.

### Battery Replacement (Fig. 4, page 5)

1. Open the battery compartment cover on the rear of the remote control unit. The cover should open easily if you press on it with your thumb and slide it in the direction of the arrow.
2. Place two "AA" size dry batteries in the battery compartment in accordance with the diagram in the compartment, then replace the cover.

Incorrect use of batteries may lead to leakage or rupture. Be sure to follow these guidelines:

- A. Always insert batteries into the battery compartment correctly matching the positive (+) and negative (-) polarities as shown in the diagram inside the compartment.
- B. Never mix new and used batteries together.
- C. Both rechargeable and non-rechargeable batteries are available. Be sure to use your batteries in accordance with the instructions provided on the cells.

### Repairs

Only the most competent and qualified service technicians should be allowed to service the C-383. The Luxman company and its factory-trained warranty station personnel have the knowledge and special equipment needed for repair and calibration of this precision instrument.

In the event of difficulty, call the Luxman Authorized Service Station nearest your home or business. In many cases, the dealer where you purchased your Luxman unit will be equipped to provide service.

If you encounter a problem, please review the items in the following checklist. Also, be sure to thoroughly check other connected components, such as power

amp, speakers, turntable, CD player, TV, cassette deck, equalizer, etc.

PROBLEM	PROBABLE CAUSE AND SOLUTION
Power does not come on.	<ul style="list-style-type: none"> <li>• Check AC power cord to ensure good connection at AC outlet.</li> </ul>
No sound.	<ul style="list-style-type: none"> <li>• Incorrect input selected. Check input leads on rear panel (be sure they match input selected).</li> <li>• Line inputs and outputs of a connected tape deck are reversed.</li> <li>• SIGNAL PROCESSOR OUT/IN jumper bars are removed. Replace.</li> <li>• "VOLUME" control (item #6) is set at its minimum position.</li> </ul>
No record signal.	<ul style="list-style-type: none"> <li>• Incorrect settings of "REC OUT SELECTOR" (item #15).</li> </ul>
Remote inoperative.	<ul style="list-style-type: none"> <li>• Check "AA" batteries. See page15.</li> <li>• Reset unit. Unplug power cord for 15 seconds. Then replug.</li> </ul>



Pre-out Level/Impedance (PRE-OUT) ..... 1.0 V/20 ohms

Total Harmonic Distortion (CD Input):  
 1 kHz, 2 V ..... 0.003%

Input Sensitivity/Impedance:  
 Phono (MM) ..... 2.5 mV/47 kohms  
           (MC) ..... 200  $\mu$ v/100 ohms  
 CD, TUNER, LD, AV, VCR, TAPE-1, TAPE-2 ..... 150 mV/47 kohms  
 Video ..... 1 VP-P/75 ohms

Signal-to-Noise Ratio (IHF "A"):  
 Phono (MM/MC) ..... 91/76 dB  
 CD, TUNER, LD, AV, VCR, TAPE-1, TAPE-2 (2 V) ..... 106 dB

Frequency Response:  
 Phono (RIAA) ..... 20 Hz to 20 kHz (+0, -3 dB)  
 CD, TUNER, LD, AV, VCR, TAPE-1, TAPE-2 ..... 10 Hz to 100 kHz (+0.2, -0.8 dB)

Tone Control Range:  
 Bass (at 100 Hz) .....  $\pm$ 8 dB  
 Treble (at 10 kHz) .....  $\pm$ 8 dB

Loudness Compensation:  
 (at 100 Hz) ..... +6 dB  
 (at 10 kHz) ..... +4 dB

**General**

Power Supply ..... 230 V, 50 Hz

Dimensions (W  $\times$  H  $\times$  D) ..... 438  $\times$  125  $\times$  363 mm

Weight:  
 (Net) ..... 7.0 kg  
 (Gross) ..... 8.6 kg

**Supplied Accessories**

- RA-383 remote control unit (1)
- Size "AA" batteries (2)
- Audio phono-plug cord (1)
- Control cord (1)

Design and specifications are subject to change without notice.



## **LUX CORPORATION, JAPAN**

1-8, 1-Chome, Nishigotanda, Shinagawa-ku, Tokyo 141, Japan

Tel: 03-3493-4381 Facsimile: 03-3494-8426

68P21552W76-O  
Printed in Japan  
Imprimé au Japon